

GEROMIN

RIA monoblocco

2026

RIA

monoblocco

Catalistino

Catalogue and price list - Catalogue et liste des prix

Gli articoli del presente listino sono da considerarsi spedibili in 1/2 settimane lavorative.

Products in this price list are expected to be shipped within 1/2 working weeks.

Les articles figurant dans cette liste de prix sont disponibles dans en 1/2 semaine ouvrables.

Stabilimenti industriali

Industrial factories - Établissements industriels

3 aree operative si estendono su una superficie di 30.000 m², da cui ogni anno vengono spediti in tutto il mondo oltre 80.000 prodotti costruiti per durare nel tempo. Negli stabilimenti di Gruppo Geromin la cultura del Made in Italy convive con sistemi produttivi di nuova generazione e a basso impatto ambientale, con la ricerca di nuovi design e funzionalità, e con un'organizzazione logistica all'avanguardia, per garantire massima qualità ed efficienza, dalla progettazione alla consegna.

3 operating areas extend over a surface of 30,000 m², from which more than 80,000 products are shipped all over the world every year. Made in Italy culture coexists in the Geromin Group's factories with new generation and low environmental impact production systems, with research into new design and functionality, and with an advanced logistics set-up to guarantee maximum quality and efficiency, from design to delivery.

3 zones opérationnelles s'étendent sur une surface de 30 000 m², d'où sont expédiés chaque année dans le monde entier plus de 80 000 produits conçus pour durer. Dans les sites industriels du Groupe Geromin, la culture du Made in Italy coexiste avec des systèmes de production de nouvelle génération à faible impact environnemental, avec la recherche de nouveaux designs et de nouvelles fonctionnalités, et avec une organisation logistique de pointe pour garantir une qualité et une efficacité maximales, depuis la conception jusqu'à la livraison.



HAFRO - SAUNA VITA

CERAMICHE DI HAFRO

GEROMIN

3 brand per un unico grande gruppo

3 brands for one great group - Trois marques pour un grand groupe

HAFRO
WELLNESS & SHOWER

Il brand Hafro produce vasche idromassaggio, piatti doccia, minipiscine e spa di design, box doccia multifunzione, colonne doccia con generatore di vapore, sistemi doccia completi, sanitari e lavabi in ceramica. Prodotti Made in Italy caratterizzati da materiali di pregio, che offrono prestazioni di altissimo livello.

Hafro brand produces hydromassage tubs, shower trays, designer spas, multifunction shower cabins, shower columns with steam generator, complete shower systems, sanitaryware and ceramic washbasins. Made in Italy products characterised by high quality materials, offering the highest performance level.

La marque Hafro produit des baignoires d'hydromassage, des receveurs de douche, des mini-spas et des spas design, des cabines de douche multifonctions, des colonnes de douche avec générateur de vapeur, des systèmes de douche complets, des articles sanitaires et des lavabos en céramique. Des produits fabriqués en Italie, caractérisés par des matériaux de haute qualité, offrant le plus haut niveau de performance.

SAUNAVITA
SAUNA & HAMMAM

Sauna Vita è il brand che realizza saune finlandesi e biosaune, hammam, sistemi wellness completi di sauna-bagno turco e doccia integrata, docce emozionali e generatori di vapore per spazi domestici e per spa professionali. Ogni soluzione è studiata al minimo dettaglio per la progettazione della Spa ideale.

Sauna Vita is the brand that produces Finnish saunas and biosaunas, hammams, wellness systems complete with sauna/turkish bath and integrated shower, sensory showers and steam generators for domestic spaces and professional spas. Each solution is studied in detail to design the ideal spa.

Sauna Vita est la marque qui crée des saunas et biosaunas finlandais, des hammams, des systèmes de bien-être complets avec sauna/bain turc et douche intégrée, des douches d'expérience et des générateurs de vapeur pour les espaces domestiques et les spas professionnels. Chaque solution est étudiée dans les moindres détails pour concevoir le spa idéal.

GEROMIN
BATHROOM & LAUNDRY

Il brand Geromin produce arredo bagno e lavanderia con materiali innovativi e di alto valore estetico. L'ampia scelta di finiture e colori, uniti alle infinite possibilità di personalizzazione, permettono di rendere gli ambienti di servizio della casa sempre più funzionali, completi e coordinati.

Geromin brand produces bathroom and laundry furniture with innovative materials of high aesthetic value. The wide choice of finishes and colours, together with the countless possibilities of customisation, allow us to create the most functional, complete and co-ordinated service environments at home.

La marque Geromin produit des meubles de salle de bains et de buanderie avec des matériaux innovants et de haute valeur esthétique. Le vaste choix de finitions et de couleurs, associé aux possibilités infinies de personnalisation, permet de rendre les zones de service de la maison plus fonctionnelles, plus complètes et mieux coordonnées.

RIA

Con il suo attualissimo minimalismo propone un insieme di elementi dedicati alla praticità, incontrando le varie necessità d'arredo contemporaneo.

With its highly contemporary minimalism, it offers a set of elements designed for practicality, meeting the various needs of modern furnishings.

Avec son minimalisme très contemporain, il propose un ensemble d'éléments dédiés à la praticité, répondant aux diverses exigences de l'ameublement moderne.





Ria 101
L 100 x P 46 cm
Alto Matt Castoro

La collezione Ria monoblocco

Ria monoblock collection | La collection monobloque Ria

Ria
61x46
Pag. 08

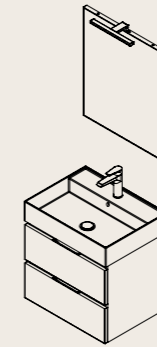

Ria
81x46
Pag. 09

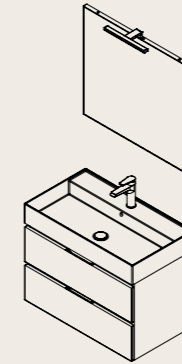

Ria
101x46
Pag. 10-15

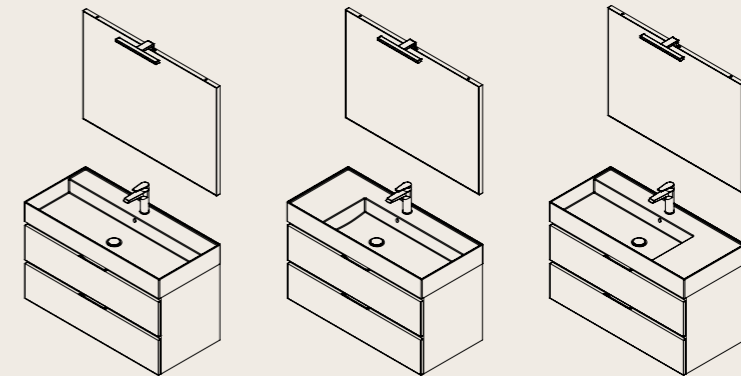

Ria
121x46
Pag. 16-19

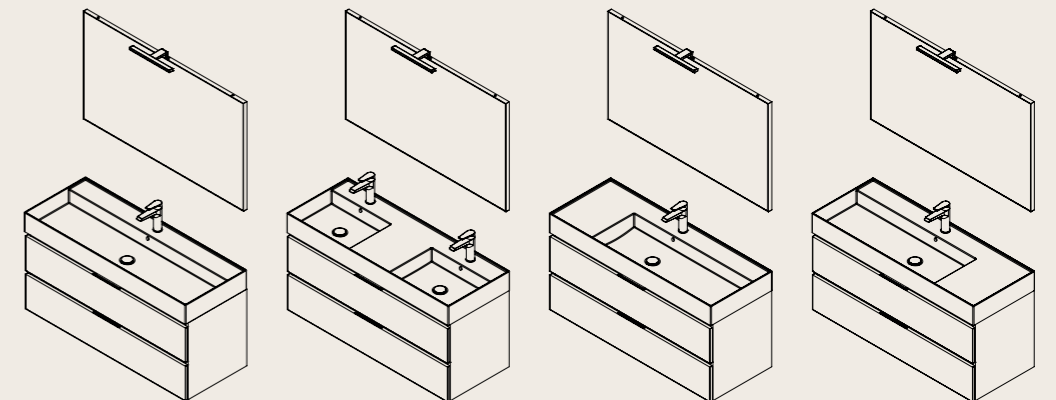



Ria 61
 L 60 x P 46 cm
 Sablè Naturale



Ria 81
 L 80 x P 46 cm
 Alto Matt Grigio Lava



Gruppo Geromin

Ria 101
L 100 x P 46 cm
Ares Grigio



Ria 101
L 100 x P 46 cm
Ares Grigio



Ria 101
L 100 x P 46 cm
Alto Matt Castoro



Ria 101
 L 100 x P 46 cm
 Sablè Grigio



Ria 101
 L 100 x P 46 cm
 Alto Matt Castoro



Ria 121
L 120 x P 46 cm
Alto Matt Lava



Ria 121
L 120 x P 46 cm
Ares Bianco



Ria 121
L 120 x P 46 cm
Alto Matt Castoro

Caratteristiche di Ria

Ria features | Caractéristiques du Ria

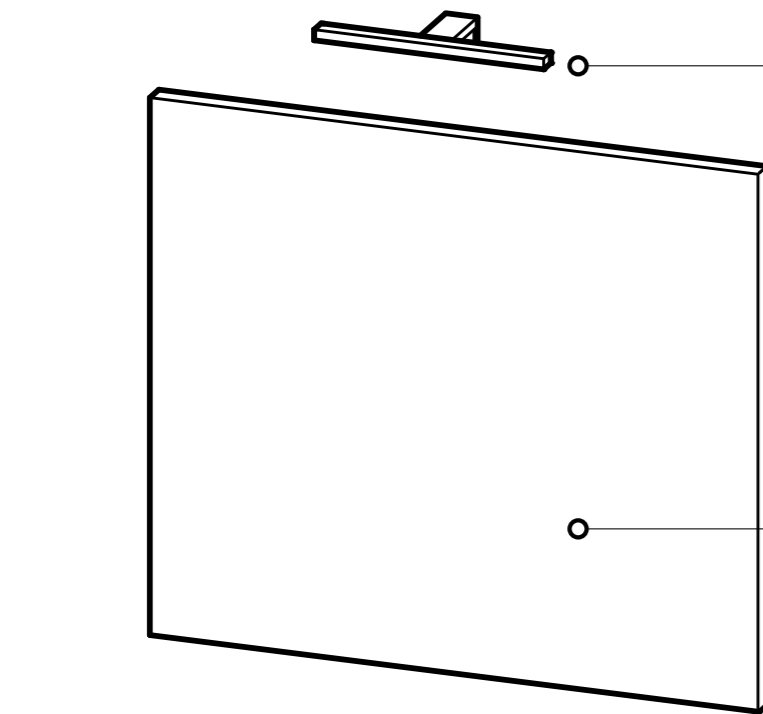

**Lampada led WIN DUE
finitura cromo, potenza 4,4 W,
alimentazione 220V, intensità
200 Lumen (4000 K).**

Led light WIN DUE
Chrome finish, power 4,4 W,
supply 220V, intensity 200
Lumen (4000 K).

Lampe à led WIN DUE
finition chrome, puissance 4,4 W
alimentation 220V, intensité 200
Lumen (4000 K).

**Specchio 4 mm, telaio PVC estruso,
attaccaglie regolabili in acciaio.**

Extruded PVC frame, 4mm mirror,
adjustable steel wall fixing.

Miroir 4 mm ,cadre en PVC extrudé
crochets réglables en acier.

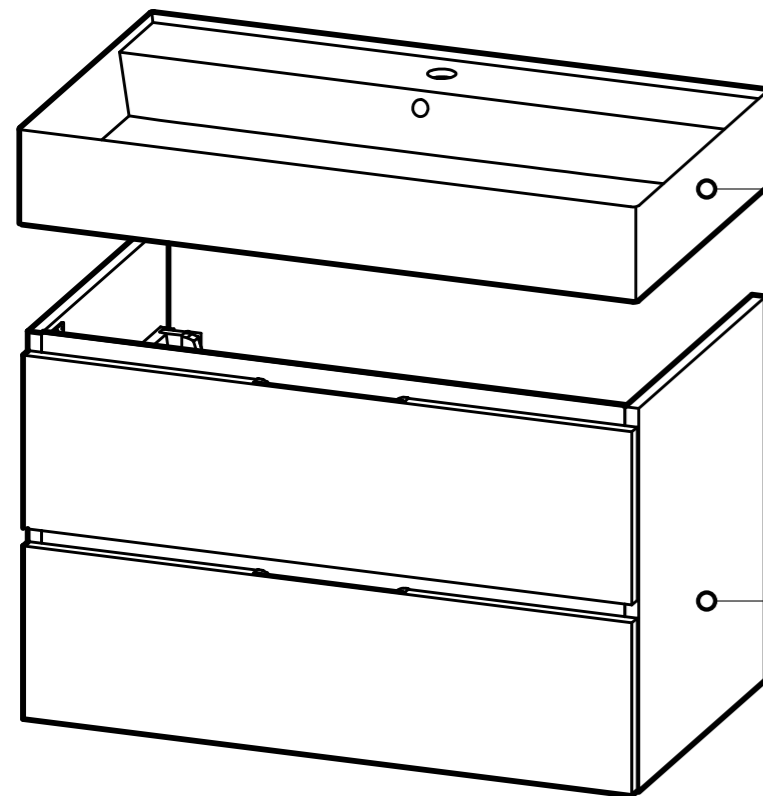

**Consolle LIRA in ceramica
bianca lucida con troppopieno.
Foro rubinetto di serie.
Completa di sistemi di fissaggio
Fischer WST-KLIK.**

LIRA Console in glossy white
ceramic with overflow.
Tap hole as standard.
Complete with Fischer WST-KLIK
fixing systems.

Console LIRA en céramique
blanche brillante avec trop-plein.
Orifice pour robinet de série.
Console complète avec systèmes
de fixation Fischer WST-KLIK.

**Base lavabo
in truciolare idrorepellente V100
in classe E1, rivestito melaminico
(spessore 1,8 cm).**

Washbasin base in water-repellent
V100 chipboard, in class E1 coated
with melamine (thickness 1.8 cm).

Base lavabo
en aggloméré hydrofuge V100
en classe E1 revêtu de mélaminé
(épaisseur 1,8 cm).

Cassetti

Drawers

Tiroirs

**Estrazione totale e chiusura ammortizzata.
Il cassetto superiore prevede spazio sifone.
Sponde nere e fondo nero. Portata massima
40 kg.**

Fully extendable drawer with soft-close
mechanism.

The top drawer has space for a siphon.
Black sides and black bottom. Maximum load
40 kg.

Tiroir à extraction totale et fermeture amortie.
Le tiroir supérieur prévoit un espace pour le
siphon.

Côtés et fond noirs. Charge maximale 40 kg.



Maniglia Pocket

Pocket handle

Poignée Pocket

Finitura maniglia

Handle finishing

Finitions poignée

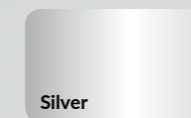

Silver

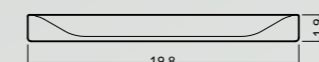



Finiture disponibili per base Ria

Available finishes for Ria base | Finitions disponibles pour la base Ria

Melaminici Sablè effetto 3D

3D effect Sablè melamine - Melaminès Sablè effet 3D

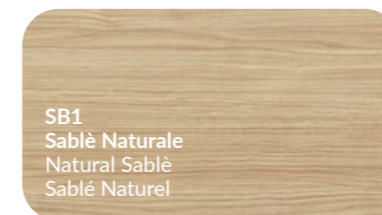

Melaminici Sherwood

Sherwood melamine - Melaminès Sherwood

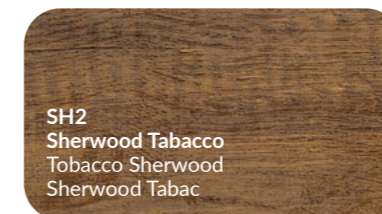

Melaminici Millinneium ed Engadina

Melamine Millennium and Engadina - Mélatinés Millennium et Engadina

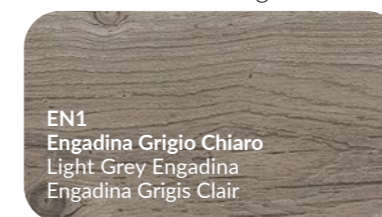
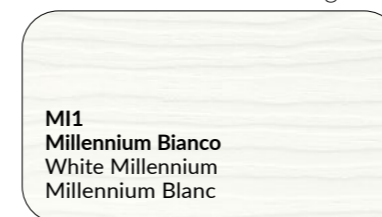

Melaminici Ares

Ares melamine - Melaminès Ares

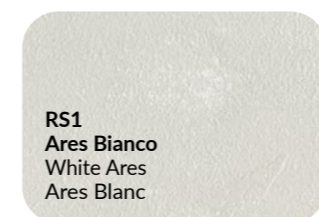

Melaminici Alto Matt Soft Touch tinta unita

Alto Matt Soft Touch plain colours Melamine - Mélatinés Alto Matt Soft Touch couleur unie

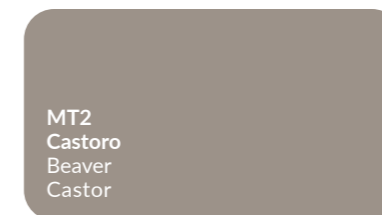
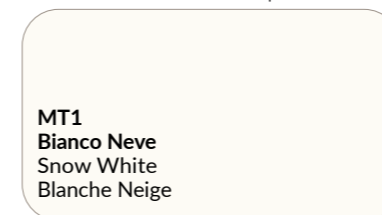

Ria 61 cm Monoblocco | Monoblock | Monobloc

Composizione monoblocco completa di base lavabo con 2 cassetti scorrevoli, consolle in ceramica bianca lucida, specchio e lampada. Rubinetteria non inclusa
* Specificare finitura melaminico

Monoblock composition complete with sink base with 2 sliding drawers, glossy white ceramic console, mirror and lamp. Taps not included
* Specify melamine finish

Composition monobloc complète avec base lavabo avec 2 tiroirs coulissants, console en ceramique blanc brillant, miroir et lampe. Robinet non inclus
* Spécifier la finition du mélaminé

Specchiera L.60 x H.70 x P.3 cm

Mirror W.60 x H.70 x D.3 cm



Miroir L.60 x H.70 x P.3 cm

Finitura melaminico
Melamine finish
Finition du mélaminé

SB1 Sablè Naturale
SB2 Sablè Bianco
SB3 Sablè Grigio
MI1 Millennium Bianco
EN1 Engadina Grigio Chiaro
SH1 Sherwood Miele
SH2 Sherwood Tabacco
RS1 Ares Bianco
RS2 Ares Grigio
RS3 Ares Visone
RS4 Ares Grafite
MT1 Altomatt Bianco Neve
MT2 Altomatt Castoro
MT3 Altomatt Grigio Lava

Listino prezzi

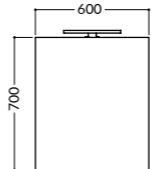
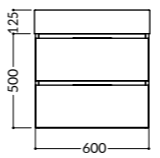
Price List | Liste de prix

ELEMENTO - ITEM - ÉLÉMENT	DESCRIZIONE - DESCRIPTION	LARG. WIDTH	PROF. DEPTH	ALTEZZA HEIGHT	CODICE - CODE	EURO
	Composizione monoblocco completa CONSOLLE VASCA CENTRALE Monoblock composition complete CENTRAL SINK CONSOLE Composition monobloc complète CONSOLE BASSIN CENTRAL	60 cm	46 cm	62,5 cm	ML3H0604*	
						

Ria 81 cm Monoblocco | Monoblock | Monobloc

Composizione monoblocco completa di base lavabo con 2 cassetti scorrevoli, consolle in ceramica bianca lucida, specchio e lampada. Rubinetteria non inclusa

* Specificare finitura melaminico

Monoblock composition complete with sink base with 2 sliding drawers, glossy white ceramic console, mirror and lamp. Taps not included

* Specify melamine finish

Composition monobloc complète avec base lavabo avec 2 tiroirs coulissants, console en ceramique blanc brillant, miroir et lampe. Robinet non inclus

* Spécifier la finition du mélaminé

Specchiera L.80 x H.70 x P.3 cm

Mirror W.80 x H.70 x D.3 cm



Miroir L.80 x H.70 x P.3 cm

Finitura melaminico

Melamine finish

Finition du mélaminé

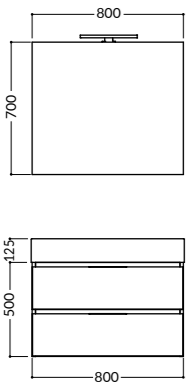
SB1 Sablè Naturale
SB2 Sablè Bianco
SB3 Sablè Grigio
MI1 Millennium Bianco
EN1 Engadina Grigio Chiaro
SH1 Sherwood Miele
SH2 Sherwood Tabacco
RS1 Ares Bianco
RS2 Ares Grigio
RS3 Ares Visone
RS4 Ares Grafite
MT1 Altomatt Bianco Neve
MT2 Altomatt Castoro
MT3 Altomatt Grigio Lava

ELEMENTO - ITEM - ÉLÉMENT	DESCRIZIONE - DESCRIPTION	LARG. WIDTH	PROF. DEPTH	ALTEZZA HEIGHT	CODICE - CODE	EURO
	<p>Composizione monoblocco completa CONSOLLE VASCA CENTRALE</p> <p>Monoblock composition complete CENTRAL SINK CONSOLE</p> <p>Composition monobloc complète CONSOLE BASSIN CENTRAL</p> 	80 cm	46 cm	62,5 cm	ML3H0804*	

Ria 101 cm Monoblocco | Monoblock | Monobloc

Composizione monoblocco completa di base lavabo con 2 cassetti scorrevoli, consolle in ceramica bianca lucida, specchio e lampada. Rubinetteria non inclusa

* Specificare finitura melaminico

Monoblock composition complete with sink base with 2 sliding drawers, glossy white ceramic console, mirror and lamp. Taps not included

* Specify melamine finish

Composition monobloc complète avec base lavabo avec 2 tiroirs coulissants, console en ceramique blanc brillant, miroir et lampe. Robinet non inclus

* Spécifier la finition du mélaminé

Specchiera L.100 x H.70 x P.3 cm

Mirror W.100 x H.70 x D.3 cm







Miroir L.100 x H.70 x P.3 cm

Finitura melaminico

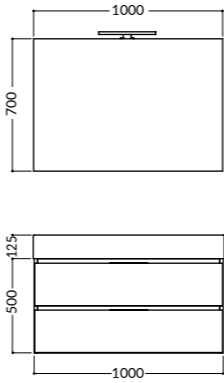
Melamine finish

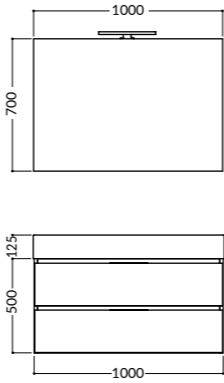
Finition du mélaminé

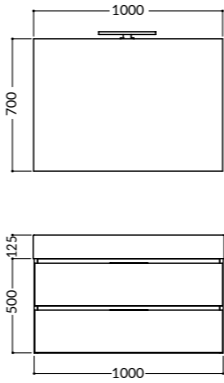
SB1 Sablè Naturale
SB2 Sablè Bianco
SB3 Sablè Grigio
MI1 Millennium Bianco
EN1 Engadina Grigio Chiaro
SH1 Sherwood Miele
SH2 Sherwood Tabacco
RS1 Ares Bianco
RS2 Ares Grigio
RS3 Ares Visone
RS4 Ares Grafite
MT1 Altomatt Bianco Neve
MT2 Altomatt Castoro
MT3 Altomatt Grigio Lava

ELEMENTO - ITEM - ÉLÉMENT	DESCRIZIONE - DESCRIPTION	LARG. WIDTH	PROF. DEPTH	ALTEZZA HEIGHT	CODICE - CODE	EURO
	<p>Composizione monoblocco completa CONSOLLE VASCA CENTRALE</p> <p>Monoblock composition complete CENTRAL SINK CONSOLE</p> <p>Composition monobloc complète CONSOLE BASSIN CENTRAL</p> 	100 cm	46 cm	62,5 cm	ML3H1004*	
	<p>Composizione monoblocco completa CONSOLLE VASCA DESTRA</p> <p>Monoblock composition complete RIGHT SINK CONSOLE</p> <p>Composition monobloc complète CONSOLE BASSIN DROITE</p> 	100 cm	46 cm	62,5 cm	ML3H1004S*	
	<p>Composizione monoblocco completa CONSOLLE VASCA CENTRALE</p> <p>Monoblock composition complete LEFT SINK CONSOLE</p> <p>Composition monobloc complète CONSOLE BASSIN GAUCHE</p> 	100 cm	46 cm	62,5 cm	ML3H1004D*	

Ria 121 cm Monoblocco | Monoblock | Monobloc

Composizione monoblocco completa di base lavabo con 2 cassetti scorrevoli, consolle in ceramica bianca lucida, specchio e lampada. Rubinetteria non inclusa

* Specificare finitura melaminico

Monoblock composition complete with sink base with 2 sliding drawers, glossy white ceramic console, mirror and lamp. Taps not included

* Specify melamine finish

Composition monobloc complète avec base lavabo avec 2 tiroirs coulissants, console en ceramique blanc brillant, miroir et lampe. Robinet non inclus

* Spécifier la finition du mélaminé

Specchiera L.120 x H.70 x P.3 cm

Mirror W.120 x H.70 x D.3 cm



Miroir L.120 x H.70 x P.3 cm

Specificare finitura

Specify finish

Spécifier la finition

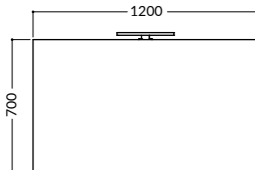
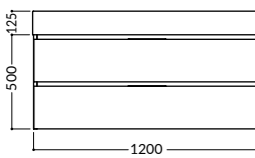
SB1 Sablè Naturale
SB2 Sablè Bianco
SB3 Sablè Grigio
MI1 Millennium Bianco
EN1 Engadina Grigio Chiaro
SH1 Sherwood Miele
SH2 Sherwood Tabacco
RS1 Ares Bianco
RS2 Ares Grigio
RS3 Ares Visone
RS4 Ares Grafite
MT1 Altomatt Bianco Neve
MT2 Altomatt Castoro
MT3 Altomatt Grigio Lava

ELEMENTO - ITEM - ÉLÉMENT	DESCRIZIONE - DESCRIPTION	LARG. WIDTH	PROF. DEPTH	ALTEZZA HEIGHT	CODICE - CODE	EURO
	<p>Composizione monoblocco completa CONSOLLE VASCA CENTRALE</p> <p>Monoblock composition complete CENTRAL SINK CONSOLE</p> <p>Composition monobloc complète CONSOLE BASSIN CENTRAL</p>	120 cm	46 cm	62,5 cm	ML3H1204*	
	<p>Composizione monoblocco completa CONSOLLE DOPPIA VASCA</p> <p>Monoblock composition complete DOUBLE SINK CONSOLE</p> <p>Composition monobloc complète CONSOLE DOUBLE BASSIN</p>	120 cm	46 cm	62,5 cm	ML3H12042*	
						
						

Ria 121 cm Monoblocco | Monoblock | Monobloc

Composizione monoblocco completa di base lavabo con 2 cassetti scorrevoli, consolle in ceramica bianca lucida, specchio e lampada. Rubinetteria non inclusa

* Specificare finitura melaminico

Monoblock composition complete with sink base with 2 sliding drawers, glossy white ceramic console, mirror and lamp. Taps not included

* Specify melamine finish

Composition monobloc complète avec base lavabo avec 2 tiroirs coulissants, console en ceramique blanc brillant, miroir et lampe. Robinet non inclus

* Spécifier la finition du mélaminé

Specchiera L.120 x H.70 x P.3 cm

Mirror W.120 x H.70 x D.3 cm



Miroir L.120 x H.70 x P.3 cm

Finitura melaminico

Melamine finish

Finition du mélaminé

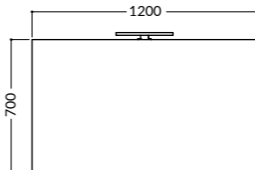
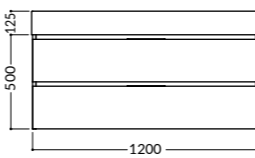
SB1 Sablè Naturale
SB2 Sablè Bianco
SB3 Sablè Grigio
MI1 Millennium Bianco
EN1 Engadina Grigio Chiaro
SH1 Sherwood Miele
SH2 Sherwood Tabacco
RS1 Ares Bianco
RS2 Ares Grigio
RS3 Ares Visone
RS4 Ares Grafite
MT1 Altomatt Bianco Neve
MT2 Altomatt Castoro
MT3 Altomatt Grigio Lava

ELEMENTO - ITEM - ÉLÉMENT	DESCRIZIONE - DESCRIPTION	LARG. WIDTH	PROF. DEPTH	ALTEZZA HEIGHT	CODICE - CODE	EURO
	<p>Composizione monoblocco completa CONSOLLE VASCA DESTRA</p> <p>Monoblock composition complete RIGHT SINK CONSOLE</p> <p>Composition monobloc complète CONSOLE BASSIN DROITE</p>	120 cm	46 cm	62,5 cm	ML3H1204S*	
	<p>Composizione monoblocco completa CONSOLLE VASCA SINISTRA</p> <p>Monoblock composition complete LEFT SINK CONSOLE</p> <p>Composition monobloc complète CONSOLE BASSIN GAUCHE</p>	120 cm	46 cm	62,5 cm	ML3H1204D*	
						
						

Elementi comuni

Common elements | Éléments communs

Colonne | Column | Colonne

Struttura melaminica sp. 1,8 cm

Anta reversibile con chiusura ammortizzata su colonne H 160 e H 100

* Specificare la maniglia: PUSH-PULL o POCKET

Specificare verso apertura anta: DX-SX

Specificare finitura melaminico

Melamine structure, thickness 1.8 cm

Reversible door with soft-close mechanism on columns H 160 e H 100

* Specify handle: PUSH-PULL or POCKET

Specify door swing direction: RH-LH

Specify melamine finish

Structure en mélamine épaisseur 1,8 cm

Porte réversible avec fermeture amortie sur colonnes H 160 et H 100

* Spécifier la poignée: PUSH-PULL ou POCKET

Spécifier inqiduer le sens d'ouverture: DR-GA



Spécifier la finition du mélaminé

Finitura melaminico

Melamine finish

Finition du mélaminé

SB1 Sablè Naturale
SB2 Sablè Bianco
SB3 Sablè Grigio
M11 Millennium Bianco
EN1 Engadina Grigio Chiaro
SH1 Sherwood Miele
SH2 Sherwood Tabacco
RS1 Ares Bianco
RS2 Ares Grigio
RS3 Ares Visone
RS4 Ares Grafite
MT1 Altomatt Bianco Neve
MT2 Altomatt Castoro
MT3 Altomatt Grigio Lava

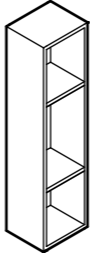
ELEMENTO - ITEM - ÉLÉMENT	DESCRIZIONE - DESCRIPTION	LARG. WIDTH	PROF. DEPTH	ALTEZZA HEIGHT	CODICE - CODE	EURO
	<p>COLONNA H 160 cm 1 anta battente, 4 ripiani in truciolare maniglia Push-Pull o Pocket. Apertura destra/sinistra (reversibile).</p> <p>COLUMN H 160 cm 1 hinged door, 4 chipboard shelves Push-Pull or Pocket handle. Right/left opening (reversible).</p> <p>COLONNE H 160 cm 1 porte battante, 4 étagères en aggloméré poignée Push-Pull or Pocket. Ouverture à droite/à gauche (réversible).</p>	35 cm	36,5 cm	160 cm	CO8A035A*	
	<p>MEZZA COLONNA H 100 cm 1 anta battente, 2 ripiani in truciolare maniglia Push-Pull o Pocket. Apertura destra/sinistra (reversibile).</p> <p>HALF COLUMN H 100 cm 1 hinged door, 2 chipboard shelves Push-Pull or Pocket handle. Right/left opening (reversible).</p> <p>DEMI-COLONNE H 100 cm 1 porte battante, 2 étagères en aggloméré poignée Push-Pull or Pocket. Ouverture à droite/à gauche (réversible).</p>	30 cm	21 cm	100 cm	MEEA0302*	
	<p>MODULO A GIORNO H 100 cm Modulo a giorno Qubo2 completo di schiena in finitura.</p> <p>OPEN MODULE H 100 cm Qubo2 open module complete with finished back.</p> <p>MODULE OUVERT H 100 cm Module ouvert Qubo2 avec dos en finition.</p>	25 cm	21 cm	100 cm	MGEP0252*	

Porta asciugamani | Towel rack | Porte-serviettes

Porta asciugamani in acciaio, disponibile nelle finiture Cromato o verniciato Nero opaco

* Specificare se il posizionamento è a DX o SX

Steel towel rack, available in Chrome or Matt Black painted finishes

* Specify if positioning is LH or RH

Porte-serviettes en acier, disponible dans les finitions Chromé ou peint Noir mat



* Indiquer si le positionnement est à DR ou à GA

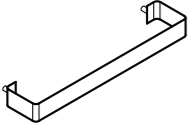
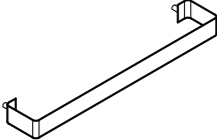

ELEMENTO - ITEM - ÉLÉMENT	DESCRIZIONE - DESCRIPTION	DIMENSIONI - DIMENSIONS	CODICE - CODE	EURO	
				Cromo Chrome Chrome	Nero Black Noir
	PER BASE Porta asciugamani a fianco mobile FOR BASE UNIT Side towel rack POUR ÉLÉMENT BAS Porte-serviettes à côté du meuble	30 x 6 cm	00PAF01*		
	PER BASE Porta asciugamani a fianco mobile FOR BASE UNIT Side towel rack POUR ÉLÉMENT BAS Porte-serviettes à côté du meuble	40 x 6 cm	00PAF02*		

Rubinetteria Rule e accessori | Rule taps and Accessories | Robinetterie Rule et Accessoires

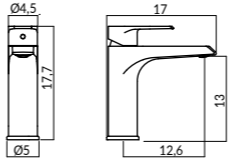

ELEMENTO - ITEM - ÉLÉMENT	DESCRIZIONE - DESCRIPTION	CODICE - CODE	EURO		
			Cromo Chrome Chrome	Nero Black Noir	Acciaio sat. Steel Acier
	Rule mix lavabo Medio (necessita di piletta Pop-up) RULE Medium washbasin mix (requires Pop-up drain plug) RULE mix lavabo Moyen (nécessite de bonde Pop-up)	00RULG2			
	Piletta pop-up Ø 4,5 cm Pop-up drain plug Ø 4,5 cm Bonde pop-up Ø 4,5 cm	00PFPG			

Area tecnica

Technical data | Domaine technique

Melaminici Sablè effetto 3D | 3D effect Sablè Melamine | Mèlaminés Sablé effet 3D

L'effetto spazzolato della finitura Sablè è tipico delle essenze lignee lavorate da abili mani artigiane, per chi ricerca la naturalezza del legno e desidera un arredobagno dall'aspetto moderno.

The brushed effect of the Sablè finish is typical of wood processed by skilled craftsmen, for those who seek the naturalness of wood and want a modern-looking bathroom furniture.

L'effet brossé de la finition Sablé est typique du bois travaillé par des artisans qualifiés, pour ceux qui recherchent le caractère naturel du bois et veulent un meuble de salle de bains à l'aspect moderne.



Melaminici Sherwood | Melamine Sherwood | Mèlaminés Sherwood

Una superficie dalla forte personalità, dai segni decisi e profondi, che prende ispirazione dalla quercia padana: la natura si esprime qui con un linguaggio deciso ed inequivocabile. Le cromie selezionate permettono a Sherwood di inserirsi sia in spazi classici che contemporanei.

A surface with a strong personality, with decisive and deep marks, inspired by the Po Valley oak: nature expresses itself here in a decisive and unequivocal language. The colours selected allow Sherwood to be used in both classic and contemporary spaces.

Une surface à forte personnalité, aux signes décisifs et profonds, inspirée par le chêne de la vallée du Pô: la nature s'exprime ici dans un langage décisif et sans équivoque. Les couleurs sélectionnées permettent d'utiliser Sherwood dans les espaces classiques et contemporains.



Melaminici Millennium | 3D effect Sablè Melamine | Mèlaminés Sablé effet 3D

La finitura Millennium esprime tutta l'estrema levigatezza e omogeneità della composizione dell'abete rosso. Ciò che caratterizza questa nuova finitura è la sua evidente fiammatura, che crea intriganti effetti visivi grazie ad una successione imprevista di livelli opachi e lucidi. È in questo contrasto che Millennium diventa disegno decorativo d'impatto.

The Millennium finish expresses all the smoothness and homogeneity of the spruce composition. What distinguishes this new finish is its distinctive flaming, which creates intriguing visual effects through an unexpected succession of matt and glossy layers. The overall result is a decorative finish with striking impact.

La finition Millennium exprime toute l'extrême douceur et l'homogénéité de la composition de l'épicéa. Ce qui caractérise cette nouvelle finition, ce sont les effets visuels intrigants créés par la succession inattendue de couches mates et brillantes. C'est dans ce contraste que Millennium devient un design décoratif saisissant.

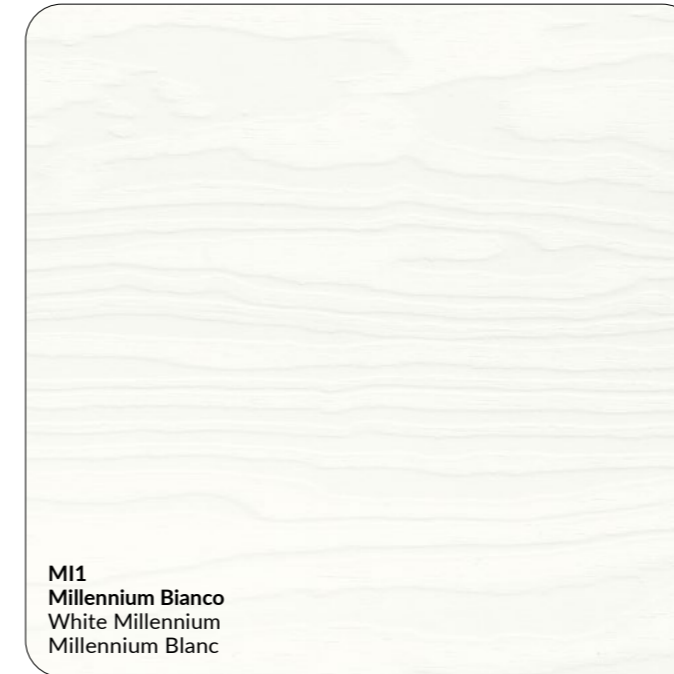

Melaminici Engadina | Melamine Engadina | Mèlaminés Engadina



Calda raffinatezza dal sapore vintage per Engadina, una nuova finitura che reinterpreta la matericità del legno rustico.

Warm sophistication with a vintage flavour for Engadina, a new finish that reinterprets the texture of rustic wood.

Une sophistication chaleureuse au goût vintage pour Engadina, une nouvelle finition qui réinterprète la matérialité du bois rustique.

Melaminici Ares

Melamine Ares | Mélaminés Ares

Ispirata alle murature urbane tipiche dell'architettura industriale, la finitura Ares riproduce l'essenzialità e la profondità di una parete in calcestruzzo o intonaco spatolato.

Inspired by the urban wall designs found in industrial architecture, the Ares finish reproduces the simplicity and depth of a concrete or plastered wall.

Inspirée des murs urbains typiques de l'architecture industrielle, la finition Ares reproduit l'essentialité et la profondeur d'un mur en béton ou en plâtre spatulé.

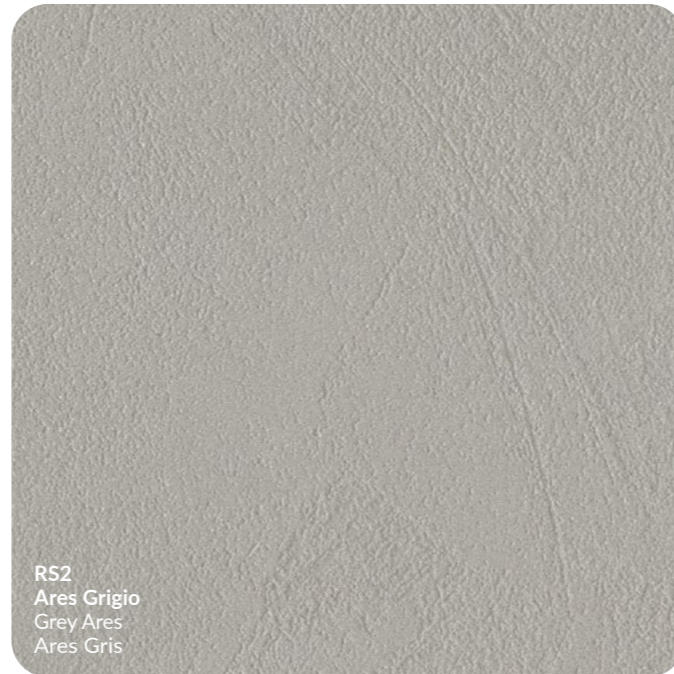
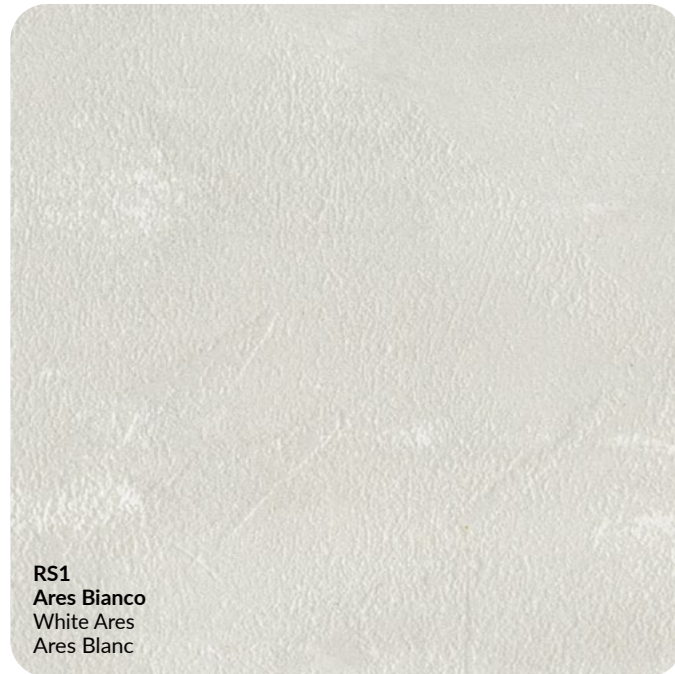

Melaminici Alto Matt Soft Touch tinta unita

Alto Matt Soft Touch plain colours Melamine | Mélaminés Alto Matt Soft Touch couleur unie

Disponibile in tre tonalità, la nuova finitura tinta unita in melaminico opaco si distingue per l'elegante effetto seta, con una texture sorprendentemente liscia e irresistibile al tatto.

Available in three colours, the new matt melamine finish is characterised by an elegant silk effect, with a surprisingly smooth texture that is irresistible to the touch.

Disponible en trois teintes, la nouvelle finition en mélamine mate se distingue par un élégant effet de soie, avec une texture étonnamment lisse et irrésistible au toucher.

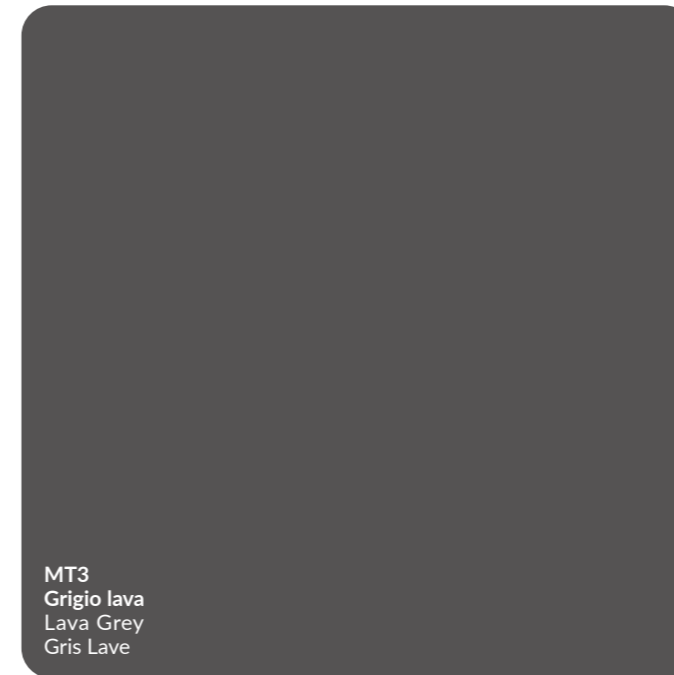
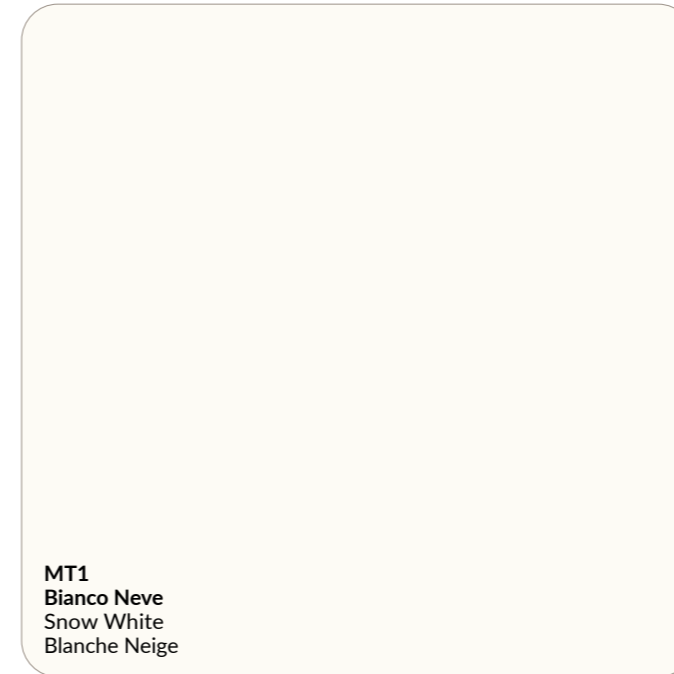

Consolle in ceramica | Ceramic consoles | Consoles en céramique

La ceramica bianco lucido dona luminosità e purezza alle superfici, trasformando la stanza da bagno in uno spazio elegante e contemporaneo. La brillantezza del bianco esalta le linee delle consolle, creando un effetto visivo raffinato e sempre attuale. Questa finitura senza tempo si abbina con facilità a ogni stile d'arredo, dai contesti moderni a quelli più classici, valorizzando l'ambiente con un tocco di essenziale sofisticatezza.

The glossy white ceramic gives brightness and purity to surfaces, transforming the bathroom into an elegant and contemporary space. The brilliance of white enhances the lines of the consoles, creating a refined and timeless visual effect. This timeless finish easily matches any style of décor, from modern to more classic contexts, enhancing the environment with a touch of essential sophistication.

La céramique blanche brillante apporte luminosité et pureté aux surfaces, transformant la salle de bains en un espace élégant et contemporain. La brillance du blanc met en valeur les lignes des consoles, créant un effet visuel raffiné et toujours actuel. Cette finition intemporelle s'harmonise facilement avec tous les styles d'ameublement, des plus modernes aux plus classiques, mettant en valeur l'environnement avec une touche de sophistication essentielle.



007
Bianco Lucido
Glossy White
Blanche Brillant









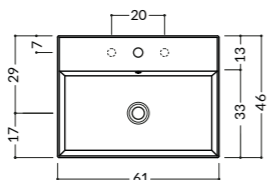
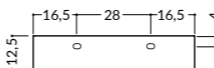

Consolle Lira in ceramica | Lira ceramic console | Console Lira en céramique

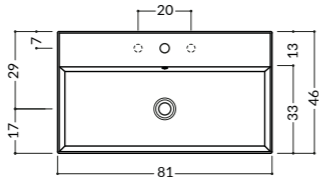
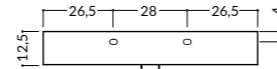
Consolle in ceramica bianca lucida con troppopieno
 Foro rubinetto di serie
 Completa di sistema di fissaggio Fischer WST-KLICK
 Piletta esclusa

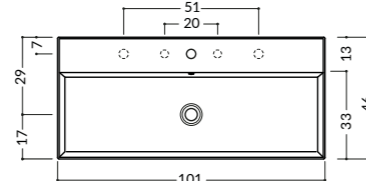
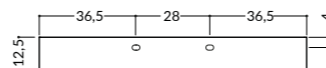
Glossy white ceramic console with overflow
 Standard tap hole
 Complete with Fischer WST-KLICK fixing system
 Drain plug not included

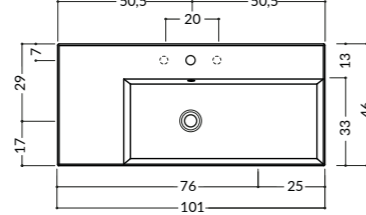
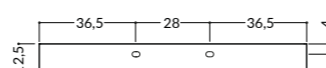
Console en céramique blanc brillant avec trop-plein
 Trou de robinet de série
 Complète avec systèmes de fixation Fischer WST-KLICK
 Bonde de vidage non inclus

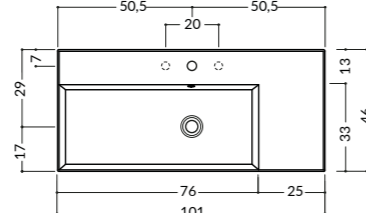
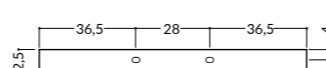





ELEMENTO - ITEM - ÉLÉMENT	PESO WEIGHT	LARG. WIDTH	DISEGNO TECNICO - TECHNICAL DRAWING - DESSIN TECHNIQUE	
	17,5 Kg	61 cm		
	20 Kg	81 cm		
	29 Kg	101 cm		
	27 Kg	101 cm		
	27 Kg	101 cm		

Consolle Lira in ceramica | Lira ceramic console | Console Lira en céramique

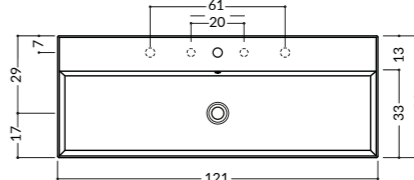
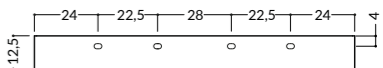
Consolle in ceramica bianca lucida con troppopieno
 Foro rubinetto di serie
 Completa di sistema di fissaggio Fischer WST-KLICK
 Piletta esclusa

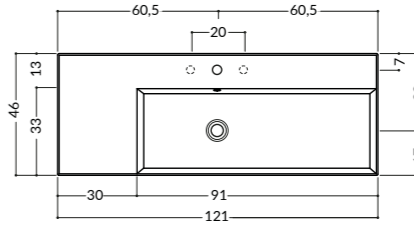
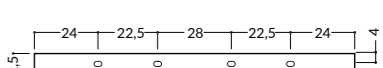
Glossy white ceramic console with overflow
 Standard tap hole
 Complete with Fischer WST-KLICK fixing system
 Drain plug not included

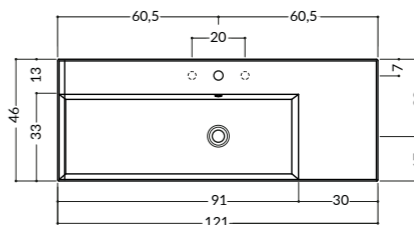
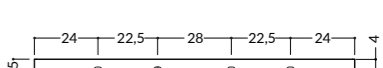
Console en céramique blanc brillant avec trop-plein
 Trou de robinet de série
 Complète avec systèmes de fixation Fischer WST-KLICK
 Bonde de vidage non inclus

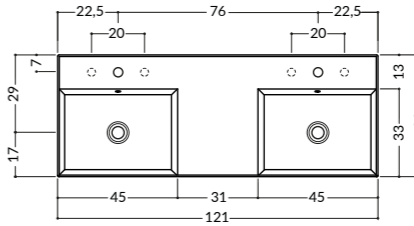
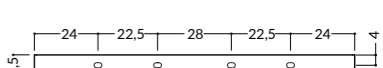
ELEMENTO - ITEM - ÉLÉMENT	PESO WEIGHT	LARG. WIDTH	DISEGNO TECNICO - TECHNICAL DRAWING - DESSIN TECHNIQUE	
	33 Kg	121 cm		
	33 Kg	121 cm		
	33 Kg	121 cm		
	33 Kg	121 cm		

Schede tecniche installazione

Installation technical datasheet | Fiches techniques d'installation

H. 50 cm con due cassetti vasca CENTRALE
 H.50 cm with two drawers CENTRAL sink
 H.50 cm avec deux tiroirs cuve CENTRALE

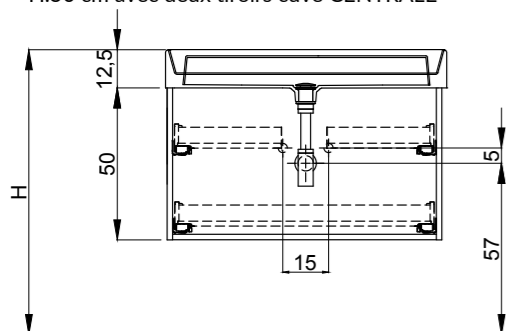

H = ALTEZZA CONSIGLIATA 87 / 89 cm
 H = RECOMMENDED HEIGHT 87/ 89 cm
 H = HAUTEUR RECOMMANDÉE 87 / 89 cm

H. 50 cm con due cassetti vasca DOPPIA
 H.50 cm with two drawers DOUBLE sink
 H.50 cm avec deux tiroirs cuve DOUBLE

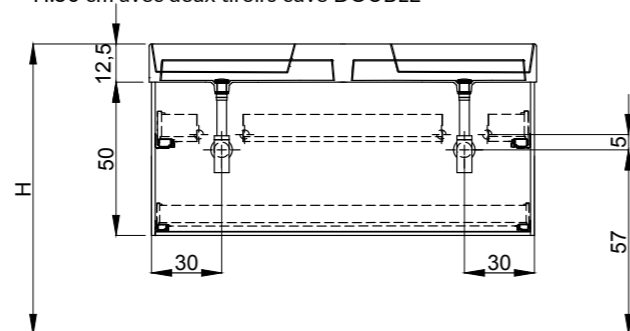

H = ALTEZZA CONSIGLIATA 87 / 89 cm
 H = RECOMMENDED HEIGHT 87/ 89 cm
 H = HAUTEUR RECOMMANDÉE 87 / 89 cm

H. 50 cm con due cassetti vasca SX
 H.50 cm with two drawers LH sink
 H.50 cm avec deux tiroirs cuve GA

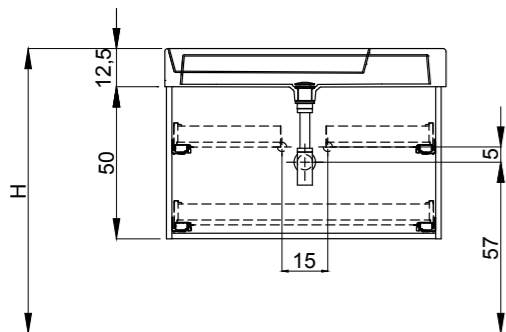

H = ALTEZZA CONSIGLIATA 87 / 89 cm
 H = RECOMMENDED HEIGHT 87/ 89 cm
 H = HAUTEUR RECOMMANDÉE 87 / 89 cm

H. 50 cm con due cassetti vasca DX
 H.50 cm with two drawers RH sink
 H.50 cm avec deux tiroirs cuve DR

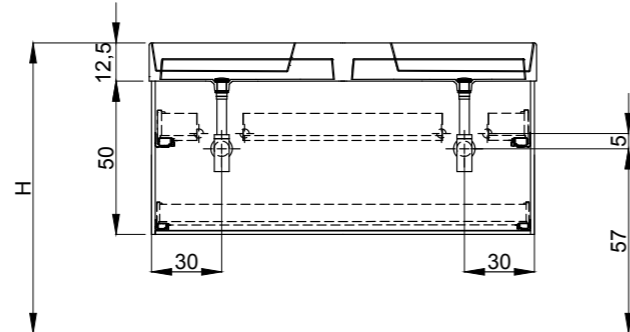

H = ALTEZZA CONSIGLIATA 87 / 89 cm
 H = RECOMMENDED HEIGHT 87/ 89 cm
 H = HAUTEUR RECOMMANDÉE 87 / 89 cm

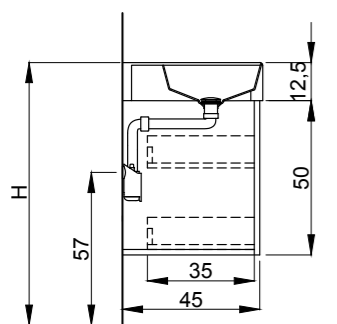

H = ALTEZZA CONSIGLIATA 87 / 89 cm
 H = RECOMMENDED HEIGHT 87/ 89 cm
 H = HAUTEUR RECOMMANDÉE 87 / 89 cm



Condizioni generali di vendita

1. DECORRENZA

Le presenti quotazioni decorrono dall'01.04.2026.

2. ORDINI

Qualsiasi ordine è impegnativo per il committente; lo diventa per Gruppo Geromin Srl solo a seguito di specifica conferma scritta.

3. ANNULLAMENTO ORDINI

L'annullamento di un ordine implica l'accettazione scritta da parte di Gruppo Geromin Srl. Gruppo Geromin Srl si riserva la facoltà di addebitare al committente tutti gli oneri conseguenti.

4. TEMPI DI CONSEGNA

I tempi di consegna indicati sulla conferma d'ordine sono meramente indicativi; in caso di ritardo non è riconosciuto alcun indennizzo.

I tempi di consegna sono espressi in giorni: gli stessi devono essere intesi come giorni lavorativi (da lunedì a venerdì).

La consegna dell'ordine si intende evasa all'atto della presa in carico del prodotto, presso il magazzino Gruppo Geromin Srl, da parte del vettore incaricato del trasporto. Nessuna responsabilità sarà riconducibile a Gruppo Geromin Srl e nulla sarà riconosciuto all'acquirente qualora la mancata consegna non sia attribuibile all'azienda stessa. A mero titolo esemplificativo: ritardi di terzi (inclusi fornitori e subfornitori), cause di forza maggiore come mobilitazioni, scioperi, chiusure, incidenti, guasti alle macchine, eventi metereologici o comunque in genere qualsiasi altro caso che comporti l'inattività o il rallentamento degli stabilimenti aziendali.

5. PAGAMENTI

Le condizioni di pagamento, se non diversamente indicate in fattura, sono le seguenti:

- vendite nazionali: 30 gg df, in presenza di una linea di credito accordata; diversamente, pagamento anticipato all'atto della consegna;

- vendite export: lettera di credito irrevocabile confermata da primario istituto di credito italiano.

I prodotti forniti rimangono di proprietà di Gruppo Geromin Srl fino all'avvenuto completo pagamento in conformità agli art. 1523 e seguenti del Codice Civile.

6. RECLAMI

Il cliente che riceve un prodotto danneggiato durante il trasporto deve firmare la bolla di consegna con riserva di controllo, specificando la tipologia di danno riscontrato e comunicare a Gruppo Geromin Srl, entro il termine di 8 giorni, a mezzo lettera mail o lettera raccomandata, il danno rilevato.

7. RESI

I resi devono essere espressamente autorizzati da Gruppo Geromin Srl. In ogni caso restano a carico del committente gli oneri relativi al trasporto, nonché i costi amministrativi quantificati nella cifra minima del 25% del valore di fatturazione. Non si accettano resi riguardanti prodotti realizzati su specifica richiesta.

8. GARANZIA

I prodotti del listino "Monoblocco Ria" hanno una garanzia di 24 mesi a decorrere dalla data di consegna. In caso di reclamo è richiesta la prova di acquisto. La garanzia impegna Gruppo Geromin Srl solamente alla riparazione e/o sostituzione degli elementi difettosi, sono dunque escluse ulteriori richieste da parte del cliente, ed esclude qualsivoglia risarcimento derivato dal disagio, costo oppure onere relativo accessorio.

Gruppo Geromin Srl declina ogni responsabilità per errata o cattiva installazione del prodotto fornito. La presente garanzia non è valida in caso di usura generale o nel caso in cui venga giudicato da Gruppo Geromin Srl accidentalmente danneggiato, erroneamente utilizzato o oggetto di cattiva pulizia/manutenzione.

La garanzia non è trasferibile nel caso in cui il prodotto venga reinstallato in una diversa posizione.

Gruppo Geromin Srl consiglia di avvalersi di personale qualificato in rispetto delle norme in materia. Un'installazione corretta del prodotto garantisce la maggior durata nel tempo dello stesso.

9. PREZZI

I prezzi del listino "Monoblocco Ria" sono espressi in unità di EURO.

I prezzi del presente listino sono Iva esclusa e per merce resa franco fabbrica.

L'installazione dei prodotti è sempre esclusa e deve avvenire a cura dell'utilizzatore finale.

Gruppo Geromin Srl si riserva la facoltà di variare i prezzi di listino senza obbligo di preavviso.

10. DATI TECNICI e CAMPIONI

I dati tecnici relativi ai prodotti illustrati nel presente listino sono puramente indicativi. Gruppo Geromin Srl si riserva la facoltà di apportare tutte le modifiche che riterrà opportune. Sussistono margini di tolleranza dovuti a variazioni del prodotto o dei campioni (colori, materiali, misure), causate da fattori ambientali (umidità, luce, ecc.) o fattori naturali indì per cui la conformità al campione non deve intendersi in senso tassativo.

I dépliant hanno carattere puramente illustrativo.

11. COPYRIGHT

I prodotti di Gruppo Geromin Srl sono distribuiti e disponibili per l'acquisto solo ed esclusivamente tramite la rete di rivenditori e distributori autorizzati.

Le immagini relative ai prodotti di Gruppo Geromin Srl costituiscono parte integrante della proprietà. Qualsiasi utilizzo di dette immagini può essere autorizzato esclusivamente dietro concessione scritta da parte di Gruppo Geromin Srl.

12. FORO COMPETENTE

Per qualsiasi controversia è esclusivamente competente il foro di Pordenone.

CONDIZIONI DI VENDITA IN "E-COMMERCE"

1. I prodotti del listino "Monoblocco Ria" potranno essere posti in vendita con uno sconto massimo del 30% dal listino in vigore, esclusa IVA, trasporti e costi accessori;

2. Le spese di trasporto, IVA e ulteriori costi accessori, dovranno essere separati dal prezzo del prodotto offerto, in modo tale da rendere trasparente il prezzo di vendita;

3. È severamente vietato l'utilizzo di sistemi di "asta a ribasso";

4. Potranno essere usate solo immagini ufficiali provenienti dal catalogo. L'uso di altre immagini dovrà essere autorizzato da Gruppo Geromin Srl.

Le foto sono puramente dimostrative. Riferirsi alle schede tecniche per dettagli tecnici.

Gruppo Geromin Srl si riserva il diritto di apportare modifiche al prodotto in qualsiasi momento senza darne alcun preavviso.

General conditions of sale

1. DECORRENCE

These quotations shall take effect on 01.04.2026.

2. ORDERS

Any order is binding on the customer; it becomes binding on Gruppo Geromin Srl only upon specific written confirmation.

3. ORDERS CANCELLATION

The cancellation of an order implies written acceptance by Gruppo Geromin Srl. The company reserves the right to charge the customer for all consequential charges.

4. DELIVERY TIME

Delivery times indicated on the order confirmation are merely indicative; in case of delay, no compensation is recognized. Delivery times are expressed in days: the same should be understood as working days (Monday to Friday).

Order delivery is intended to be fulfilled when the product is taken in charge, at the Gruppo Geromin Srl warehouse, by the carrier in charge of transport.

No responsibility will be attributable to Gruppo Geromin Srl and nothing will be recognized to the purchaser if the non-delivery is not attributable to the company itself.

Purely by way of example: delays by third parties (including suppliers and sub-suppliers), force majeure causes such as mobilizations, strikes, closures, accidents, machine failures, weather events or in general any other case that results in the inactivity or slowdown of the company's factories.

5. PAYMENTS

Payment terms, unless otherwise stated on the invoice, are as follows:

- sales in Italy: payment due within 30 days of the invoice date where there is an approved credit line; otherwise, payment due upon delivery;

- international sales: irrevocable letter of credit confirmed by a major Italian bank.

Products supplied remain the property of Gruppo Geromin Srl until full payment has been made in compliance with art. 1523 et seq. of the Italian Civil Code.

6. COMPLAINTS

The customer who receives a product damaged during transport must sign the delivery note with reserve of control, specifying the type of damage found and communicate to Gruppo Geromin Srl, within the period of 8 days, by mail or registered letter, the damage found.

7. RETURNS

Returns must be expressly authorised by Gruppo Geromin Srl. In any case, charges related to transportation as well as administrative costs quantified in the minimum figure of 25% of the invoice value shall remain the responsibility of the buyer. We do not accept returns concerning custom-made products.

8. WARRANTY

Products in the "Monobloc Ria" price list have a 24-month warranty from the date of delivery. Proof of purchase is required in case of a claim.

The warranty commits Gruppo Geromin Srl only to the repair and/or replacement of the defective items, further claims by the customer are therefore excluded, and excludes any compensation derived from the inconvenience, cost or relative ancillary charges. Gruppo Geromin Srl disclaims any liability for incorrect or improper installation of the supplied product. This warranty is not valid in case of general wear and tear or in case it is judged by Gruppo Geromin Srl to be

accidentally damaged, misused, or subject to poor cleaning/maintenance.

The warranty is not transferable if the product is reinstalled in a different location.

Gruppo Geromin Srl recommends the use of qualified technicians in compliance with the relevant regulations. Correct installation of the product guarantees the longest life of the product.

9. PRICES

Prices in the "Monobloc Ria" price list are in units of EURO.

The prices in this price list are exclusive of VAT and for goods delivered ex-works.

Installation of products is always excluded and must be undertaken by the end user.

Gruppo Geromin Srl reserves the right to change list prices without prior notice.

10. TECHNICAL DATA and SAMPLES

The technical data for the products illustrated in this price list are purely indicative. Gruppo Geromin Srl reserves the right to make any changes it deems appropriate.

There are margins of tolerance due to variations in the product or samples (colours, materials, dimensions), caused by environmental factors (humidity, light, etc.) or natural factors, therefore conformity to the sample should not be understood in an peremptory sense. Brochures are for illustrative purposes only.

11. COPYRIGHT

Gruppo Geromin Srl products are distributed and available for purchase only and exclusively through the network of authorized dealers and distributors.

The images related to Group Geromin Srl products constitute an integral part of the property. Any use of said images may be authorized only with written permission from Gruppo Geromin Srl.

12. COURT OF JURISDICTION

Any disputes will be settled by the Court of Pordenone.

TERMS AND CONDITIONS OF SALE IN "E-COMMERCE"

1. Products in the "Monobloc Ria" price list may be placed on sale at a maximum discount of 30% from the current price list, excluding VAT, transportation and ancillary costs;

2. Transportation costs, VAT and other ancillary costs, shall be separated from the price of the offered product so that the selling price is transparent;

3. The use of 'price auction' systems is strictly prohibited;

4. Only official images from the catalogue can be used. The use of other images must be authorised by Gruppo Geromin Srl.

Images are purely illustrative. Please refer to the technical datasheets for all technical specifications.

Gruppo Geromin Srl reserves the right to modify its products at any time without prior notice.

Conditions générales de vente

1. DECORRENCE

Ces cotations prennent effet le 01.04.2026.

2. COMMANDES

Toute commande passée par le client est ferme et définitive; elle le devient pour Gruppo Geromin Srl uniquement après confirmation écrite.

3. ANNULATION DES COMMANDES

L'annulation d'une commande implique l'approbation écrite de la part de Gruppo Geromin Srl. Gruppo Geromin Srl se réserve le droit de facturer au client le remboursement des frais inhérents.

4. DÉLAIS DE LIVRAISON

Les délais de livraison indiqués dans la confirmation de commande sont purement indicatifs; aucune indemnité ne sera versée en cas de retard. Les délais de livraison sont exprimés en jours: il s'agit de jours ouvrables (du lundi au vendredi).

La livraison de la commande s'entend effectuée au moment de la prise en charge du produit, dans l'entrepôt de Gruppo Geromin Srl, par le transporteur en charge du transport. Aucune responsabilité ne sera imputable à Gruppo Geromin Srl et rien ne sera reconnu à l'acheteur si le défaut de livraison n'est pas imputable à la société elle-même. A titre d'exemple: les retards de tiers (y compris les fournisseurs et les sous-fournisseurs), les causes de force majeure telles que les mobilisations, les grèves, les fermetures, les accidents, les pannes de machines, les événements météorologiques ou, en général, tout autre cas qui entraîne l'inactivité ou le ralentissement des installations de l'entreprise.

5. PAIEMENTS

Les conditions de paiement, sauf indication contraire sur la facture, sont les suivantes:

- ventes nationales: 30 jours à partir de la date d'émission de la facture, en présence d'une ligne de crédit accordée; autrement, paiement anticipé à la livraison;
- ventes à l'étranger: lettre de crédit irrévocable confirmée par une banque italienne de première importance.

Les produits livrés restent la propriété de Gruppo Geromin Srl jusqu'à leur paiement intégral, conformément aux articles 1523 et suivants du Code civil.

6. RÉCLAMATIONS

Le client qui reçoit un produit endommagé pendant le transport doit signer le bon de livraison soumis à vérification, en précisant le type de dommage constaté, et notifier à Gruppo Geromin Srl dans les 8 jours, par e-mail ou par lettre recommandée, les dommages constatés.

7. RETOURS

Les retours de marchandise doivent être exclusivement autorisés par Gruppo Geromin srl. Dans tous les cas, les frais de transport et les éventuelles charges administratives restent toutefois à la charge du client, quantifiés par le montant minimum de 25% de la valeur de la facture. Les retours concernant les produits réalisés sur demande spécifique ne sont pas acceptés.

8. GARANTIE

Les produits de la liste de prix «Monobloc Ria» sont garantis 24 mois à partir de la date de livraison. La preuve d'achat est requise en cas de réclamation. La garantie n'engage Gruppo Geromin Srl qu'à la réparation et/ou au remplacement des articles défectueux; toute autre prétention de la part du client est donc exclue, de même que tout dédommagement dérivant d'inconvénients, de coûts ou de frais accessoires. Gruppo Geromin Srl décline toute responsabilité en cas d'installation incorrecte ou mauvaise du produit fourni. Cette garantie n'est pas valable en cas d'usure générale ou si Gruppo Geromin Srl estime que le produit a été accidentellement endommagé, mal utilisé ou mal nettoyé/entretenu.

La garantie n'est pas transférable si le produit est réinstallé dans une position différente.

Gruppo Geromin Srl recommande l'utilisation d'un personnel qualifié conformément aux réglementations en vigueur. Une installation correcte du produit garantit sa longévité.

9. PRIX

Les prix figurant dans la liste de prix «Monobloc Ria» sont exprimés en euros. Ils s'entendent hors TVA et pour des marchandises livrées départ usine.

L'installation des produits est toujours exclue et doit être effectuée par l'utilisateur final. Gruppo Geromin Srl se réserve le droit de modifier les prix de la liste sans obligation de préavis.

10. CARACTÉRISTIQUES TECHNIQUES et ÉCHANTILLONS

Les données techniques relatives aux produits illustrés dans cette liste de prix sont purement indicatives. Gruppo Geromin Srl se réserve le droit d'apporter toutes les modifications qu'elle jugera opportunes. Il existe des marges de tolérance dues à des variations du produit ou des échantillons (couleurs, matériaux, mesures), causées par des facteurs environnementaux (humidité, lumière, etc.) ou naturels, la conformité à l'échantillon ne doit donc pas être comprise dans un sens absolu.

Les brochures sont purement illustratives.

11. COPYRIGHT

Les produits de Gruppo Geromin Srl sont distribués et disponibles à l'achat uniquement et exclusivement à travers le réseau de revendeurs et de distributeurs agréés. Les images relatives aux produits de Gruppo Geromin Srl font partie intégrante de la propriété. Toute utilisation de ces images ne peut être autorisée qu'avec la permission écrite de Gruppo Geromin Srl.

12. TRIBUNAL COMPÉTENT

Le tribunal défini comme compétent pour régler tout litige est celui de Pordenone.

CONDITIONS GÉNÉRALES DE VENTE DU "COMMERCE ELECTRONIQUE"

1. Les produits céramiques du catalogue "Monobloc Ria" peuvent être proposés à la vente avec une remise maximale de 30 % par rapport au tarif en vigueur, hors TVA, transport et frais annexes;

2. Les frais de transport, la TVA et les autres frais accessoires sont séparés du prix du produit offert, de manière à ce que le prix de vente soit transparent;

3. L'utilisation de systèmes de "vente aux enchères" est strictement interdite;

4. Seules les images officielles du catalogue peuvent être utilisées. L'utilisation d'autres images doit être autorisée par Gruppo Geromin Srl.

Les photos sont uniquement destinées à la démonstration. Veuillez vous référer aux fiches techniques pour les détails techniques.

Gruppo Geromin Srl se réserve le droit de modifier le produit à tout moment et sans préavis.





GRUPPO GEROMIN
VENEZIA 1945

HAFRO | SAUNAVITA | GEROMIN

GRUPPO GEROMIN Srl
Via 1° Maggio, 5 - 30029 San Stino di Livenza VE-I
TEL +39 0421 312 249
info@gruppogeromin.com www.gruppogeromin.com