

BOLLA R SFIORO 200x150

Technical Data sheet



The bath must be installed by a qualified electrician and plumber.

Before connecting the bath, the installer must see that the electrical system is protected by a circuit breaker (0.03) and that the earthing system complies with the laws in force in the country of installation.

The whirlpool bath must be connected to the electrical system permanently (with an H05 cable - 3x2.5 mm² three-pole with a 2.5 mm² cross section) by means of a double-pole switch (minimum 3 mm opening between contacts) and suitably rated (KW) for the appliance to be connected, located away from areas 0,1,2,3 and from areas where jets of water are possible.

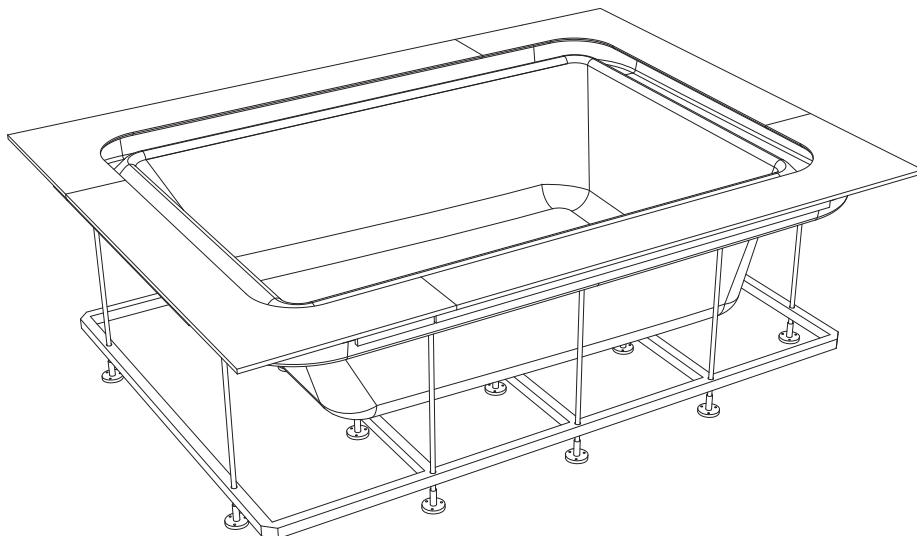

SYSTEMS	Electrical specification				Jet	Water	cont	Use	Siz	Packing			dimension		Weight	
	Volt	A	KW	Hz						Whirl	Air	length	width	height	length	width
Whirl. digitale	230	3.6 / 10.4*	0.8 / 2.3*	50	12	--	420	560	200	150	64	200	200	85	85	125
Airpool	230	3.2	0.7	50	--	24	420	560	200	150	64	200	200	85	80	114
Whirl. airpool	230	6.8 / 13.6*	1.5 / 3.0*	50	12	24	420	560	200	150	64	200	200	85	95	135
Vasca con telaio	--	--	--	--	--	--	420	560	200	150	64	200	200	85	60	104

* With option (heater 1.5kw)

Provide for the inspection panel and snorkel.

The data are to be considered without accessories.

The overall dimensions are given in centimetres. Actual dimensions can vary by ± 1 cm.

The bath must also be connected to the building's equipotential earthing system by means of a terminal on the frame. If the bath is to be recessed in walls, the guarantee will only be valid if the walls are fitted with inspection and aeration grids of a suitable size. It is also important that the bath can be taken out at any time without having to do anything to the walls.

WARNING: if all or even part of the above described conditions are not complied with the safety of the whirlpool bath cannot be guaranteed and, as such, not only is the guarantee invalidated but also the manufacturer can in no way be held liable for any direct or indirect damages caused by the bath.

In those cases where such conditions are not complied with, the guarantee will only cover the substitution of parts deemed defective and not the labour needed if the bath has to be removed.

Provide shut-off cocks out of the dimensions of the product for hot and cold water closing.

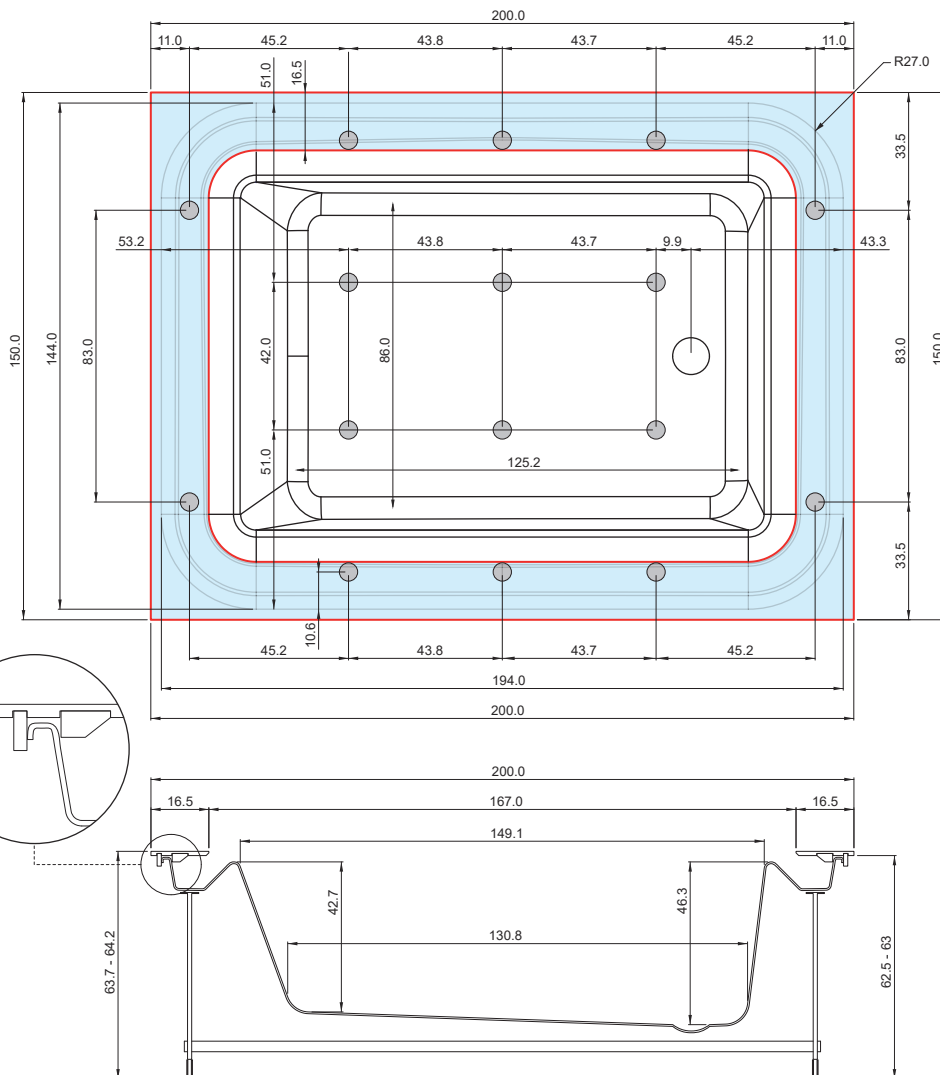



BOLLA R SFIORO 200x150

Electricity and plumbing layout

LEGEND:

A - A1 - Mixed water outlet (connects to 'attack F).

	Operating pressure:
	- MIN 150 kPa (1,5 bar)
	- MAX 300 kPa (3,0 bar)
	Hot water temperature:
	- MAX 60°C (140°F)

B - B1 - Power outlet
H05 3x2,5mm (minimum length 3 [m]).

C - C1 - Equipotential cable.

S - S1 - Flush-to-floor drain Ø 50 or wall drain Ø 50.

S2 - Safety secondary drain. ✕

PREPARE FOR TUB BUILT-IN.

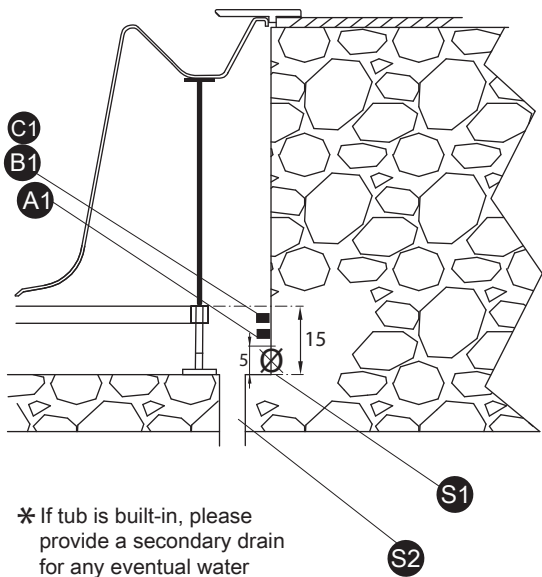

✕ If tub is built-in, please provide a secondary drain for any eventual water leaks.

If the water pressure is higher than indicated, install pressure reducers.

NOTES

Position of the outlets in the wall of the pit, haven't to be over the frame height up to 15cm.

CONDITIONS FOR PANNELED TUB.

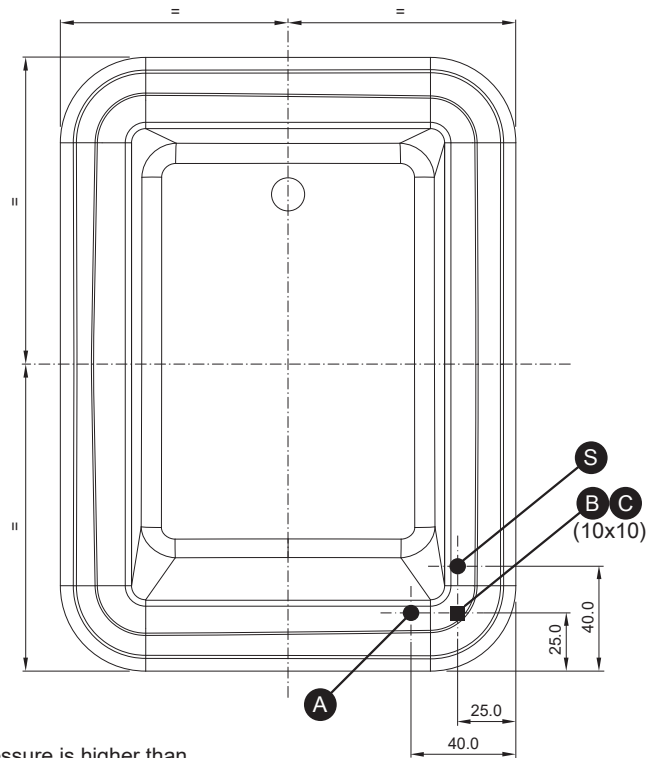

NOTES

- For tanks with frame, not predict power cord.
- In all cases, always ensure The cable to the potential equalization.

POSITIONING THE TURNING ON CONTROLS AND TAPS

OOL

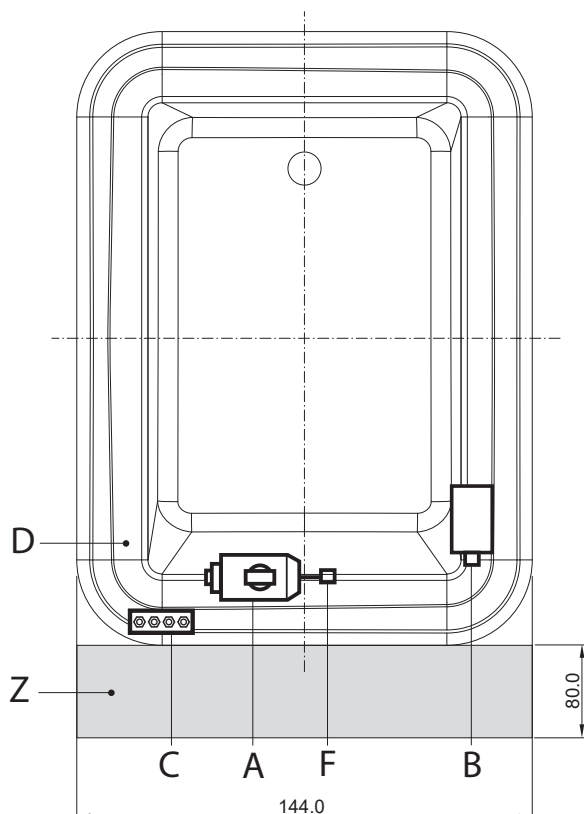

- A = Pump - Excluded Airpool bath.
- B = Blower - Excluded Whirlpool tubs-Digital.
- C = Eletronic unit.
- D = Keyboard.
- F = Water input da 1/2 ".

Z = INSPECTION AREA LOCATED UNDER THE SE AT.

**BOLLA R
SFIORO 200x150**

PREPARATION FOR BUIL - IN TUB

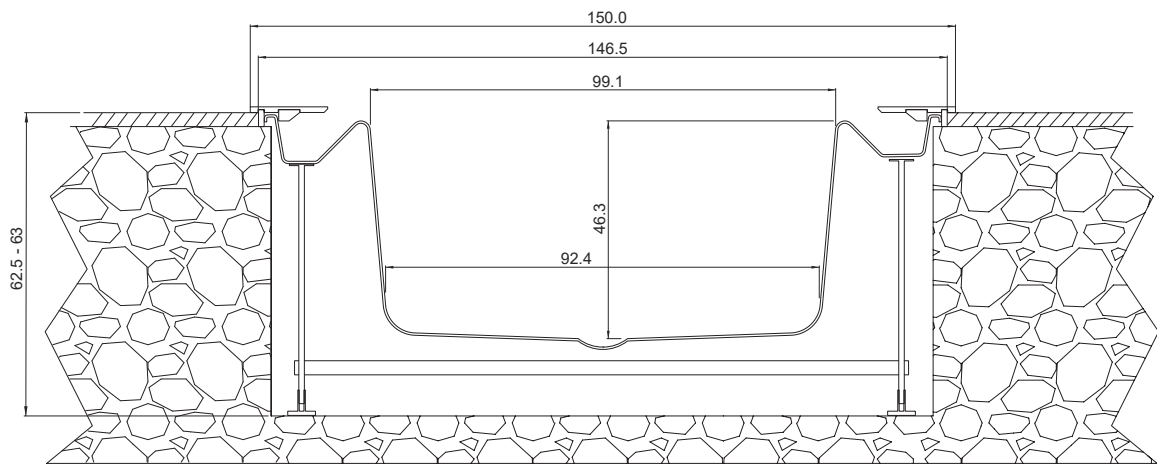
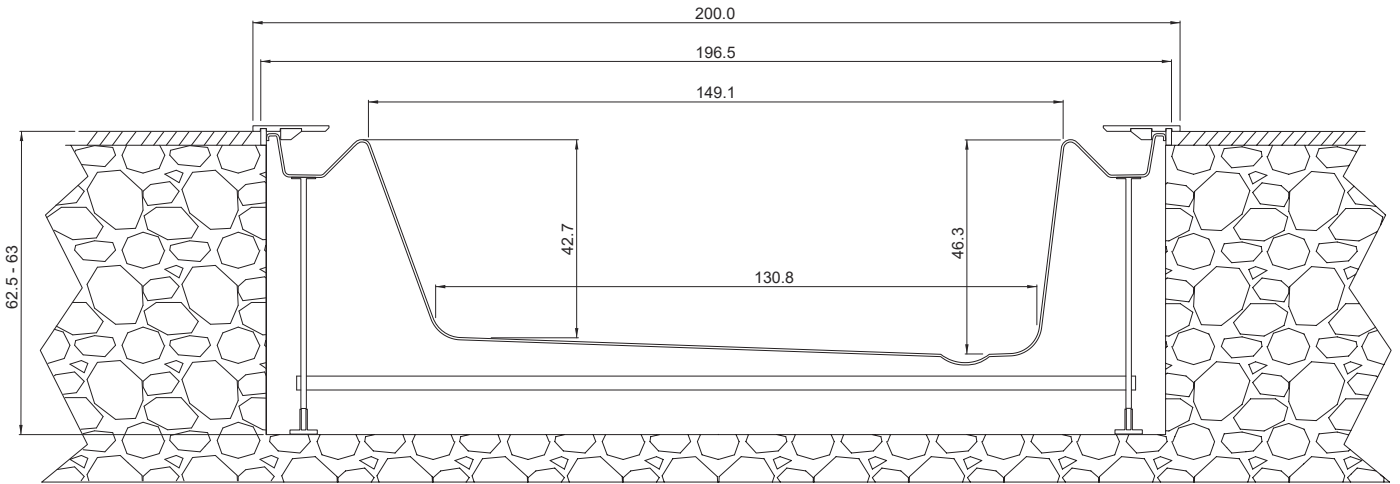

HOLE FOR FLUSH TANK

