

MOVE OVAL
170x70 FREESTANDING

TECHNICAL DATA SHEET



The installation of the tub must be performed by qualified personnel for both regarding the electronic connection that for the hydraulic one.

The overall dimensions are given in centimetres. Actual dimensions can vary by $\pm 0,5$ cm. The bath must also be connected to the building's equipotential earthing system by means of a terminal on the frame.

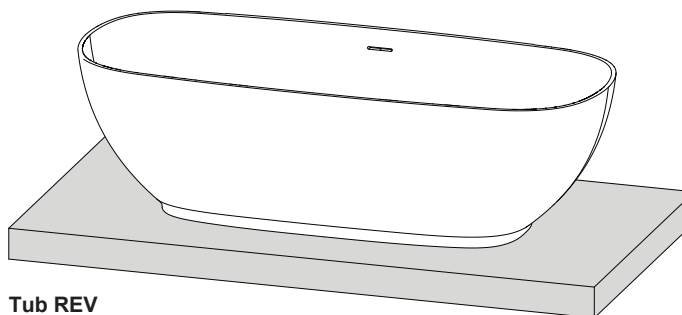

Tub REV

SYSTEM	ELETRICAL SPECIFICATIONS				JETS		WATER CONT.		PACKING DIMENSIONS				WEIGHT (KG)	
	Volt	A	W	Hz	Whirl.	Airl.	Use	Max	Lenght	Width	Height	Volume	Net	Gross
Tub with frame	-	-	-	-	-	-	275 l	370 l	180	80	70	1.0	93	103

If the bath is to be recessed in walls, the guarantee will only be valid if the walls are fitted with inspection and aeration grids of a suitable size. It is also important that the bath can be taken out at any time without having to do anything to the walls.

WARNING:

If all or even part of the above described conditions are not complied with the safety of the whirlpool bath cannot be guaranteed and, as such, not only is the guarantee invalidated but also the manufacturer can in no way be held liable for any direct or indirect damages caused by the bath. In those cases where such conditions are not complied with, the guarantee will only cover the substitution of parts deemed defective and not the labour needed if the bath has to be removed.

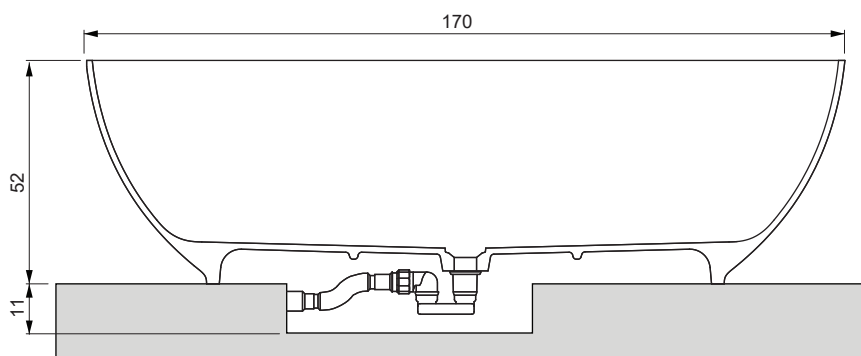
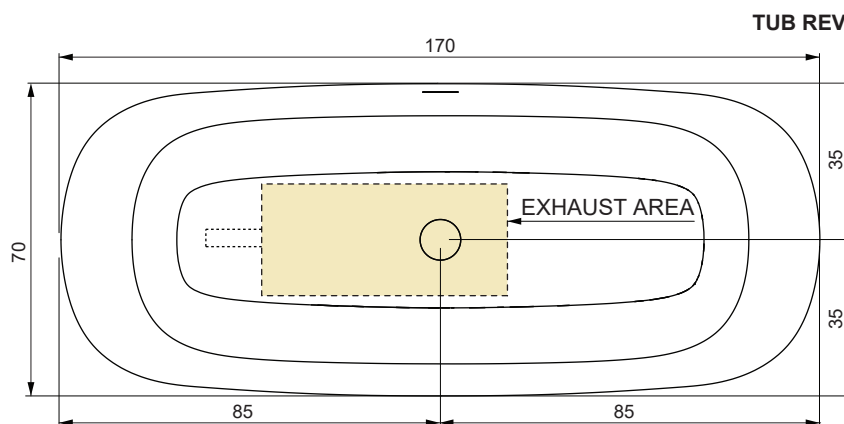

ELECTRIC AND HYDRAULIC PREPARATION

LEGEND
S - Exhaust Ø40 mm.

NOTE
- For hot and cold water connections see the technical details of the floor-mounted taps.

TUB REV

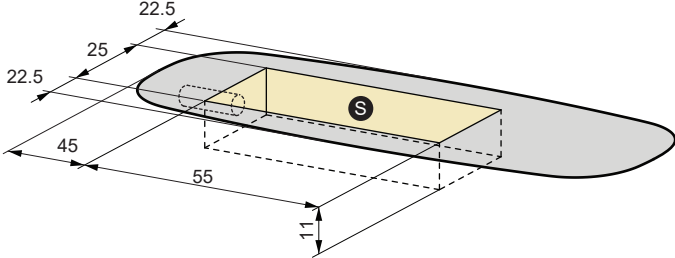
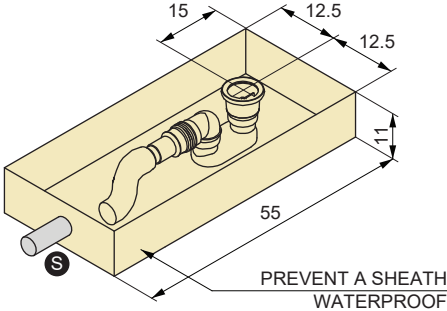

POSITIONING OF IGNITION CONTROLS AND TAPS

TAPS

