

MINERVA OUTDOOR 200x150 (with recirculation)

TECHNICAL DATA SHEET



Tubs must be installed by personnel qualified in both electrical and hydraulic connections. Before making the connections, the installer must verify that the electrical system is protected by a differential switch (0.03) and that the earthing system complies with regulations in force in the county of use.

The whirlpool tub must be connected to the electrical system in a fixed manner (with a 3-pole H05-3x2.5mm cable with a cross-section of 2.5mm) using a bipolar switch (minimum contact opening 3mm) suitable for the power (Kw) of the product to be connected and located outside zones 0, 1, 2, and 3 and away from any possible water sprays.

Panels available:
ecomalta finish

WEIGHTS:
- Faux leather cover: 13 kg
- Ecomalta panels 4/4: 50 kg

Tub with water recirculation, max flow rate tub filling solenoid valve:
2 BAR 40 l per minute, 3 BAR 50 l per minute.

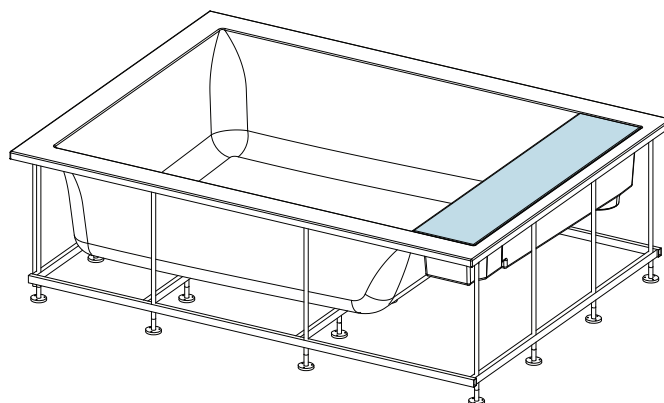

SYSTEMS	ELECTRICAL CHARACTERISTICS				JETS		WATER CONT.		PACKAGE DIM.				WEIGHT (KG)	
	Volts	A	W	Hz	Whirl.	Airl.	Use	Max	Length	Width	Height	Volume	Net	Gross
Tub with recirculation system	230	16.0	3700	50	10	16	590 l	760 l	208	158	85	2.7	150	186

2000 W heater included.

The overall dimension values are expressed in centimetres. The actual dimensions may vary by ± 1.0 cm. The product must also be connected to the building's equipotential system using the terminal located on the external frame.

If installing the tub encased between walls, the warranty will be valid only if adequate inspection grilles and ventilation are provided in the walls themselves.

It must also be possible to move the tub at any time without having to damage the walls.

WARNING:

If the conditions indicated are not observed, the safety of the tub may be compromised: in this case, the product guarantee and the manufacturer's responsibility for any direct or indirect damage caused by the product shall be void.

In the case of a voided warranty, mentioned above, only single pieces deemed defective will be replaced. Any labour costs incurred for removal of the product will not be covered.

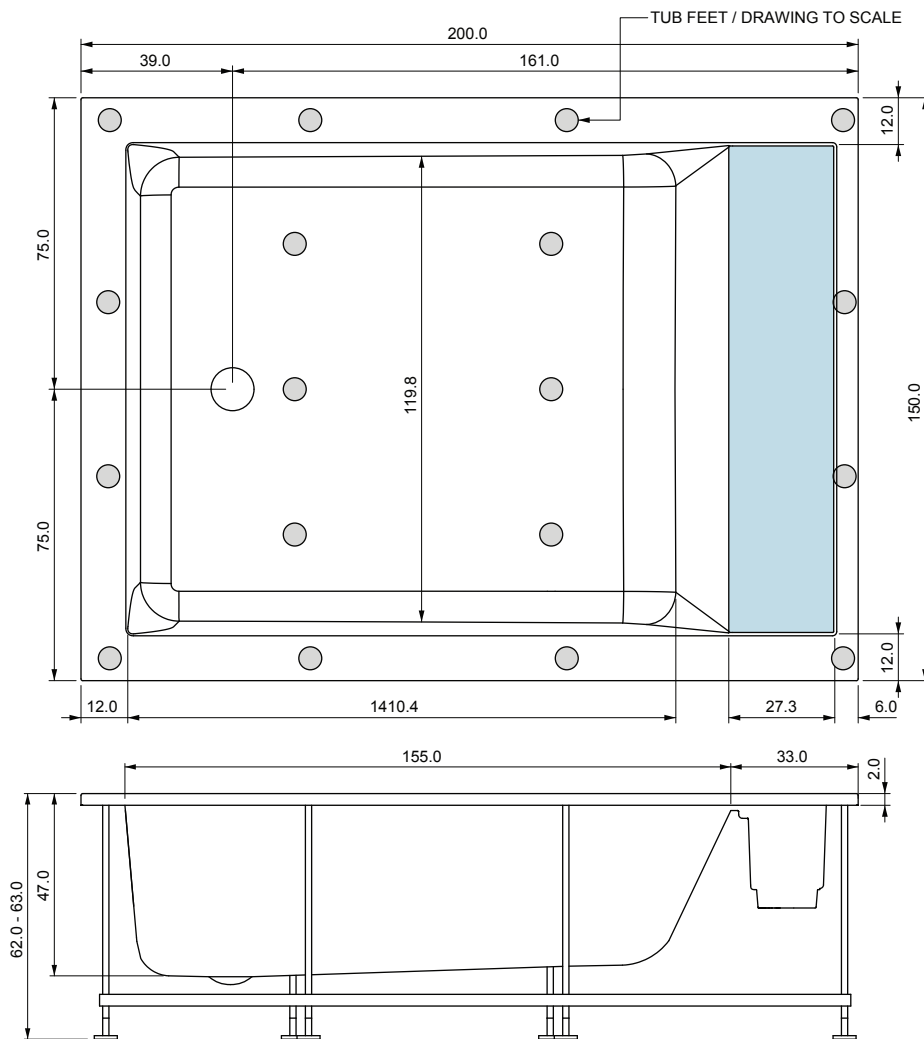

Keep the tub away from rain and snow. It must therefore be installed on verandas or terraces with a roof (flooring is necessary as it has no tray). It is important to arrange a solid foundation to withstand the maximum weight of the tank. Provide a draining bottom around it. PREPARATION FOR WINTER: During periods when the tub is not going to be in use, in the event of prolonged power failure or in periods with very low temperatures, it is important to remove all the water from the tank (including pipes), cover the tub with the insulating cover and protect the system from damage that can be caused by frost.

ELECTRICAL AND PLUMBING PROVISIONS

KEY / LEGEND:

C	Power cable outlet H05 - 3 x 2.5 mm (min. length 3m)
D	Equipotential cable.
E	1/2" M mixed water connection
S1	Tub drain diam. 40 mm.
S2	Two infinity overflow drains diam. 50 mm.
S3	Safety drain diam. 40 mm inside the "pit" for any water spillage. Provide for drainage near inspection area.
Y	Inspection area - where applicable.
H	Pre-set area for connections "C", "D", "E" to the wall (see figure to the side).

ARRANGEMENT FOR CONNECTIONS "C", "D", "E" ON THE WALL

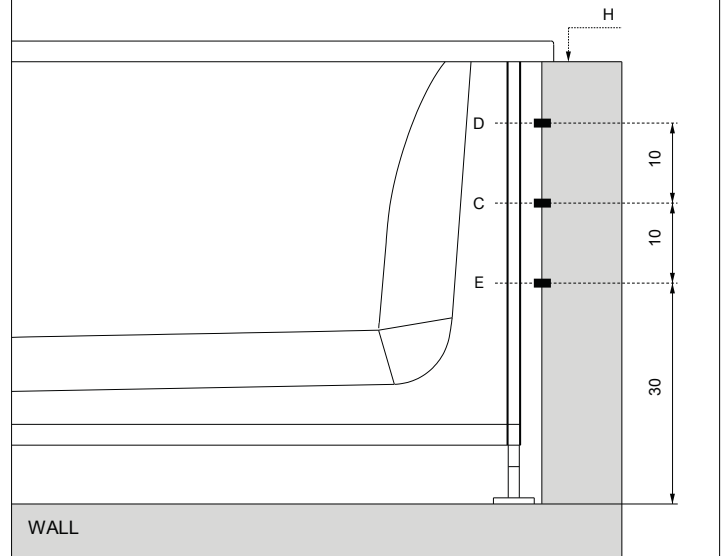

WARNINGS:

- For tubs with frame, do not provide a power cable.
- In all cases, always prepare the cable for the equipotential.
- If installing encased tubs, correct aeration is required with a grille min. diam. 15 cm.

ELECTRICAL AND PLUMBING PROVISIONS (freestanding version)

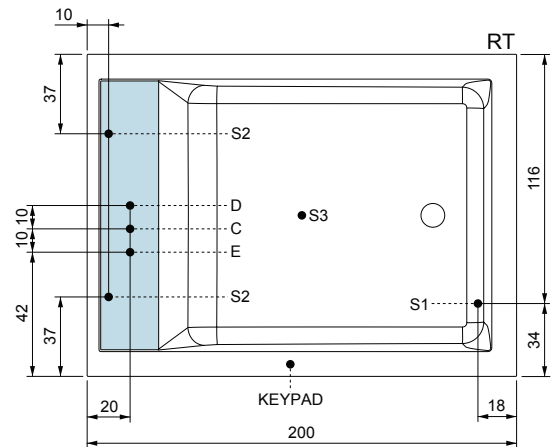
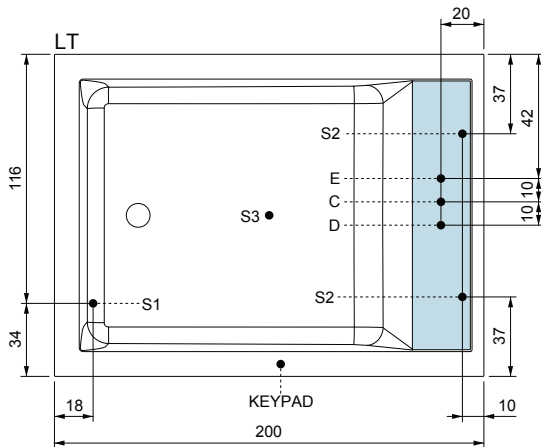

ELECTRICAL AND PLUMBING PROVISIONS (wall version)

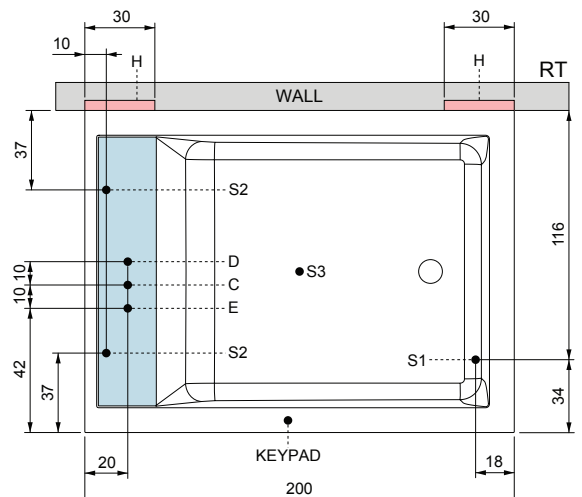
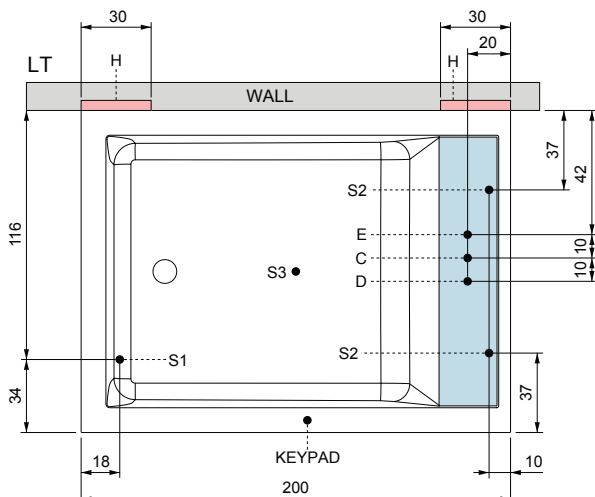

ELECTRICAL AND PLUMBING PROVISIONS (corner version)

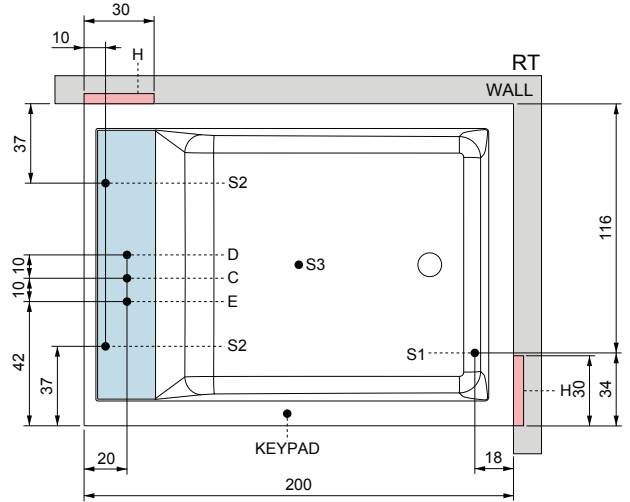
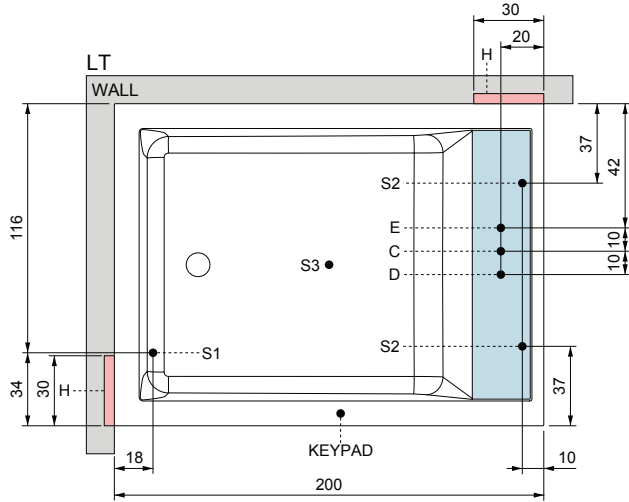

ELECTRICAL AND PLUMBING PROVISIONS (niche version)

Provide inspection area.

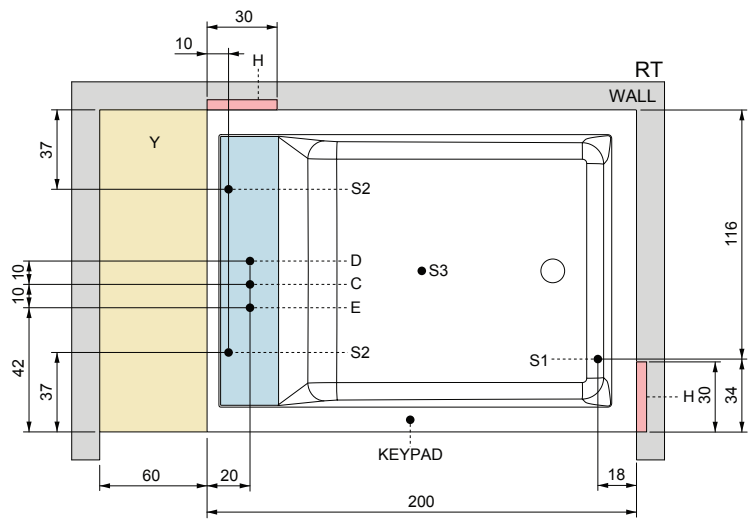
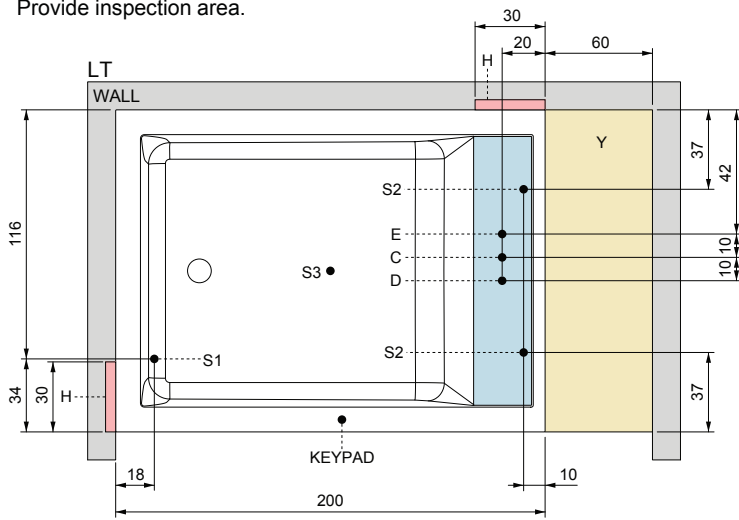

ELECTRICAL AND PLUMBING PROVISIONS (built-in version)

Provide inspection area.

