

BOLLA R SFIORO
200x150
With automatic water
recirculation system

Technical Data sheet



The bath must be installed by a qualified electrician and plumber.

Before connecting the bath, the installer must see that the electrical system is protected by a circuit breaker (0.03) and that the earthing system complies with the laws in force in the country of installation.

The whirlpool bath must be connected to the electrical system permanently (with an H05 cable - 3x2.5 mm² three-pole with a 2.5 mm² cross section) by means of a double-pole switch (minimum 3 mm opening between contacts) and suitably rated (KW) for the appliance to be connected, located away from areas 0,1,2,3 and from areas where jets of water are possible.

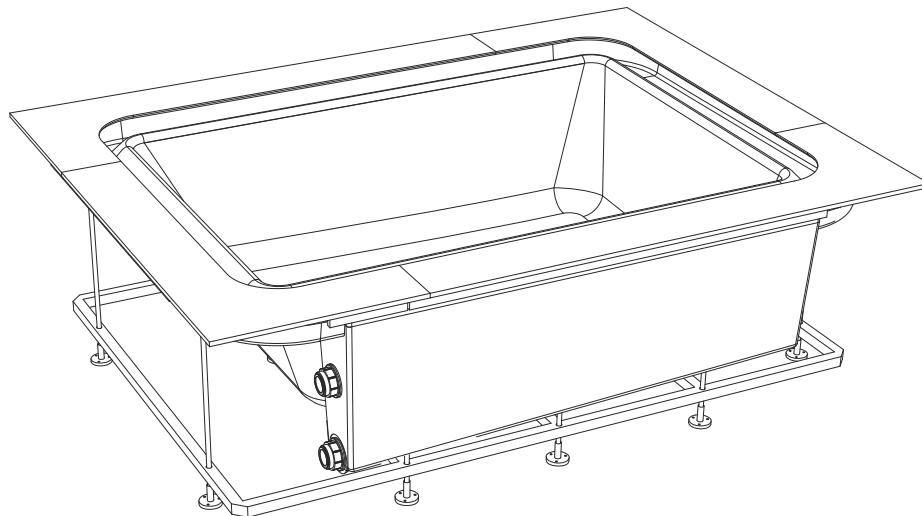

SYSTEMS	Electrical specification				Jet		Water cont		Siz			Packing dimension			Weight	
	VoIt	A	KW	Hz	Whirl	Air	Use	max	length	width.	height	length.	width.	height	net	gross
Airpool	230	20	4.3	50	--	24	420	620	200	150	64	200	200	85	105	149

Provide for the inspection panel and snorkel.

The data are to be considered without accessories.

The overall dimensions are given in centimetres. Actual dimensions can vary by ± 1 cm.

The bath must also be connected to the building's equipotential earthing system by means of a terminal on the frame. If the bath is to be recessed in walls, the guarantee will only be valid if the walls are fitted with inspection and aeration grids of a suitable size. It is also important that the bath can be taken out at any time without having to do anything to the walls.

WARNING: if all or even part of the above described conditions are not complied with the safety of the whirlpool bath cannot be guaranteed and, as such, not only is the guarantee invalidated but also the manufacturer can in no way be held liable for any direct or indirect damages caused by the bath.

In those cases where such conditions are not complied with, the guarantee will only cover the substitution of parts deemed defective and not the labour needed if the bath has to be removed.

If the bath is recessed the masonry cannot reenter more than 1 cm with respect to the external edge of the bath. An inspection panel and air intake must be installed.

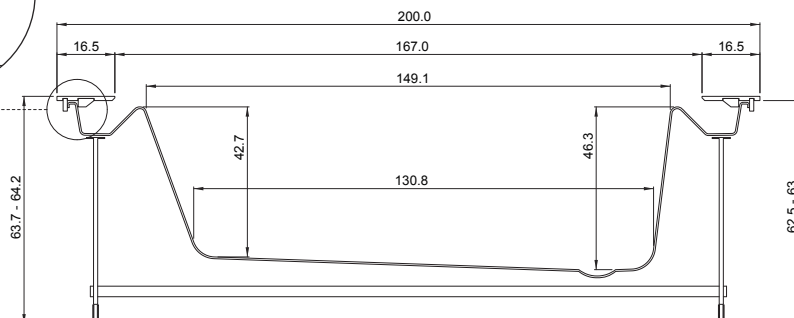
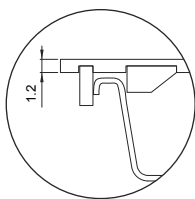
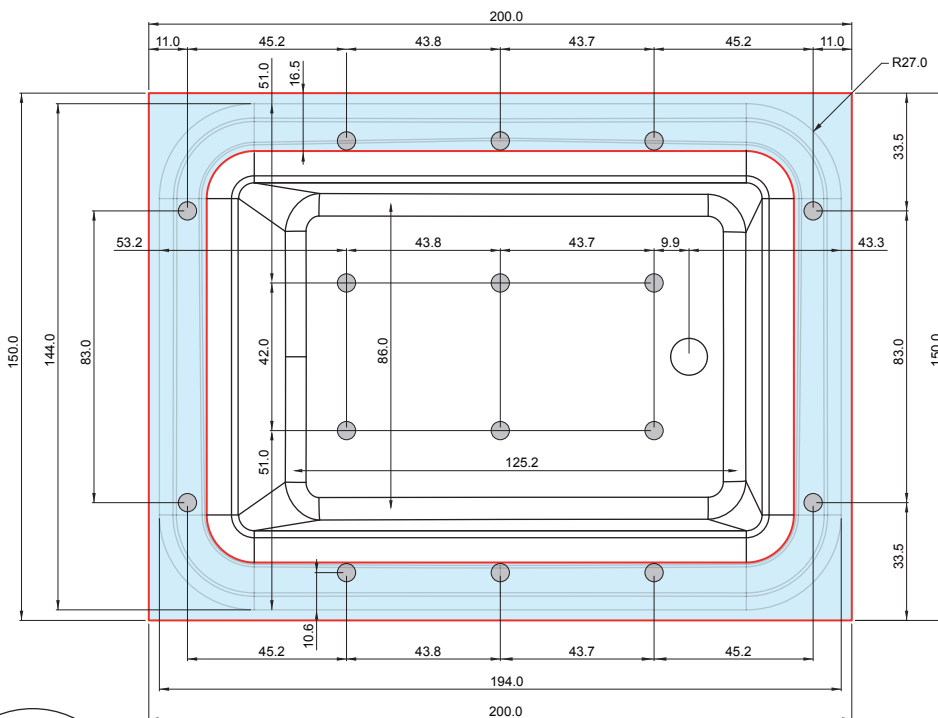

LEGEND:

- A - A1** - Mixed water outlet (connects to 'attack F).
- B - B1** - Power outlet
H05 3x2,5mm (minimum. length. 3 [m]).
- C - C1** - Equipotential cable.
- S - S1** - Flush-to-floor drain Ø 50 or wall drain Ø 50.
- S2** - Safety secondary drain.*

CONDITIONS FOR PANNELED TUB.

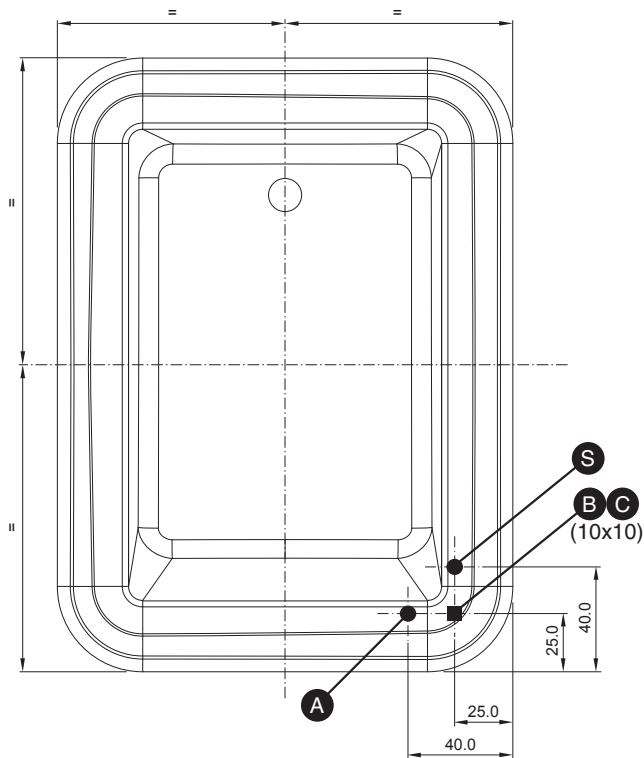

PREPARE FOR TUB BUILT-IN.

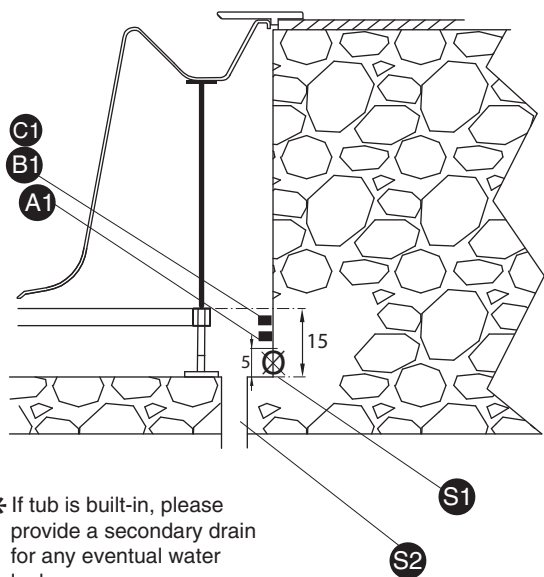

* If tub is built-in, please provide a secondary drain for any eventual water leaks.

NOTES

Position of the outlets in the wall of the pit, haven't to be over the frame height up to 15cm.

POSITIONING THE TURNING ON CONTROLS AND TAPS

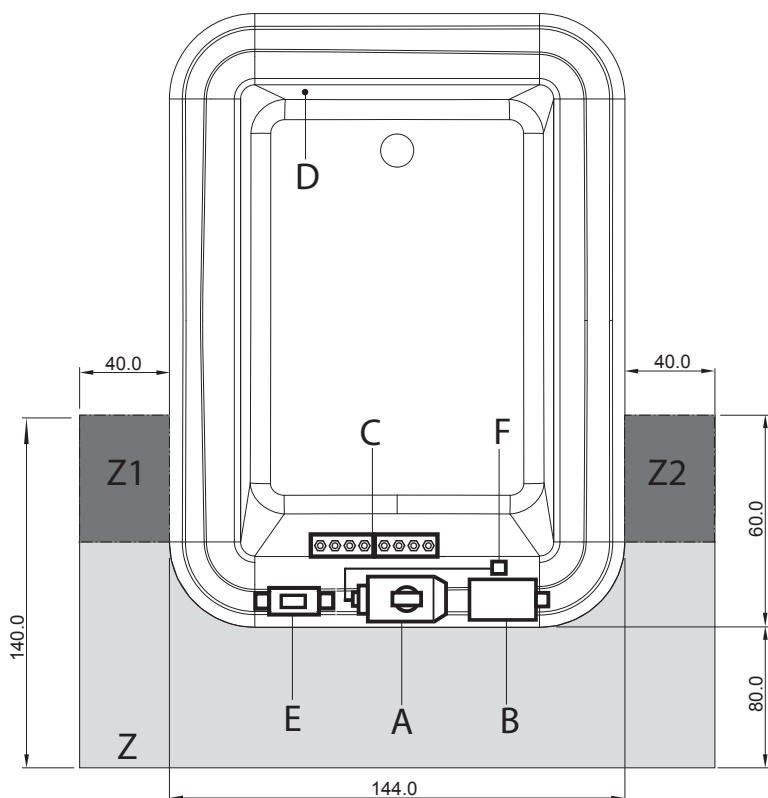

- A = Pump.**
- B = Blower.**
- C = Eletronic unit.**
- D = Keyboard.**
- F = Water input da 1/2".**
- E = Heater.**

Z = INSPECTION AREA LOCATED UNDER THE SEAT.
Z1 - Z2 = INSPECTION FOR AREA FILTERS TANK

BOLLA R SFIORO
200x150
With automatic water
recirculation system

PREPARATION FOR BUIL - IN TUB

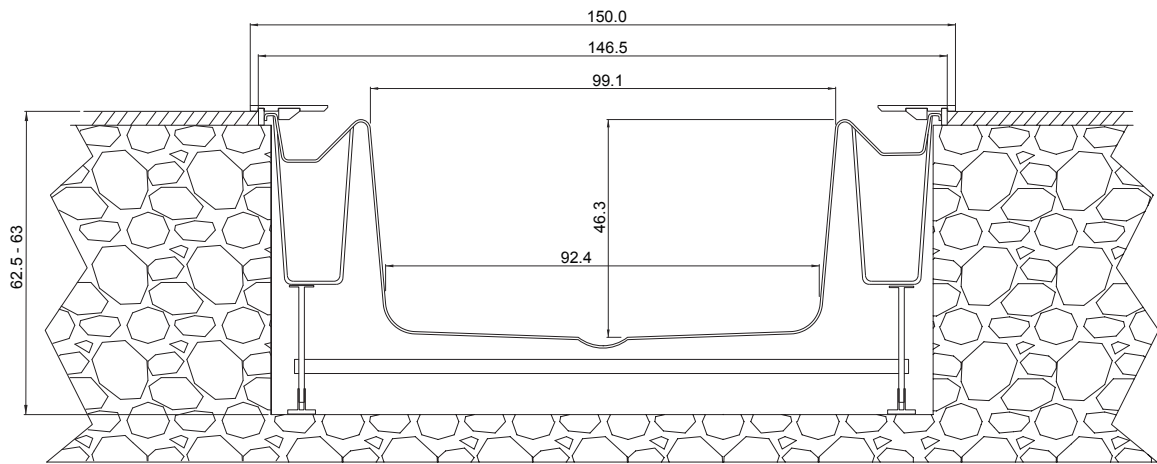
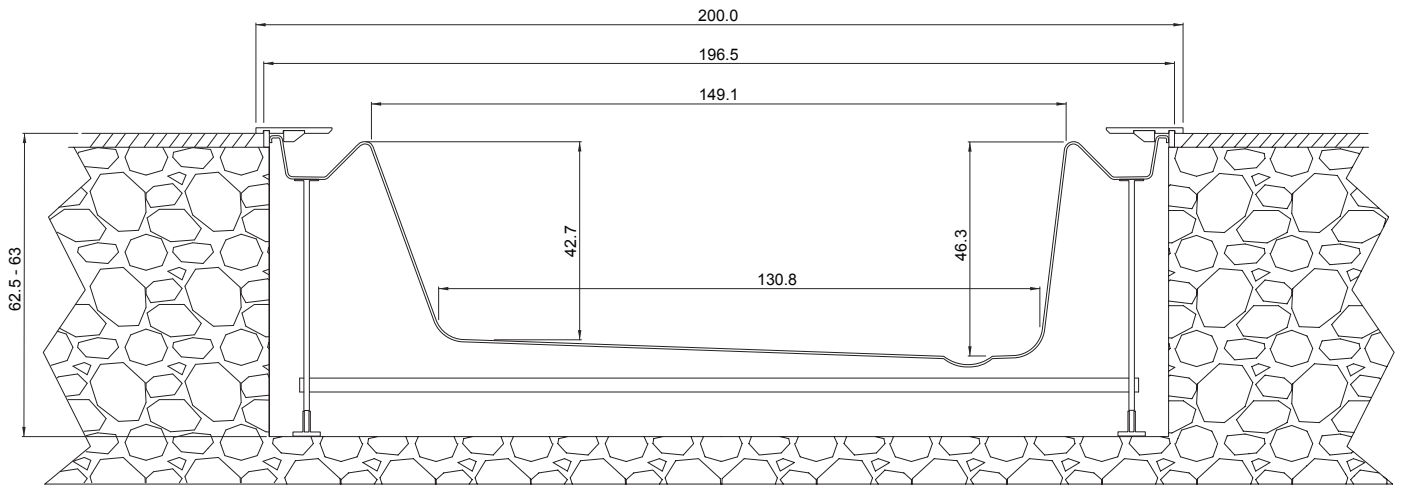

HOLE FOR FLUSH TANK

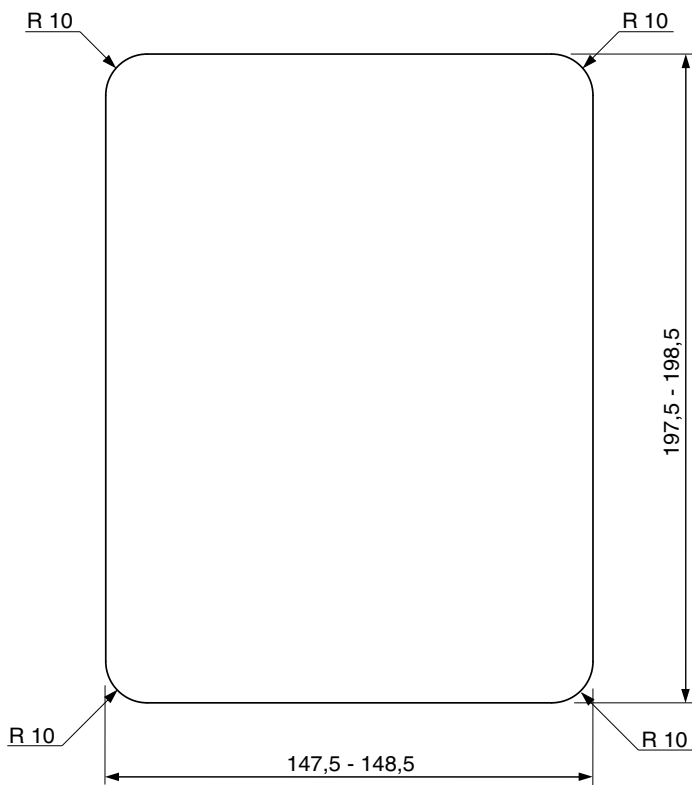

Z1 - Z2 INSPECTION FOR
AREA FILTERS TANK

