

# BOLLA SFIORO 190 x 190

# technical data sheet



The tub must be installed by personnel qualified in both electrical and hydraulic connections.

Before making the connections, the installer must verify that the electrical system is protected by a differential switch (0.03) and that the earthing system complies with regulations in force in the county of use.

The whirlpool tub must be connected to the electrical system in a fixed manner (with a 3-pole H05 -3x2.5 mm cable with a cross-section of 2.5 mm) using a bipolar switch (minimum contact opening 3 mm) suitable for the power (kW) of the product to be connected and located outside zones 0, 1, 2 and 3 and away from any possible water sprays.

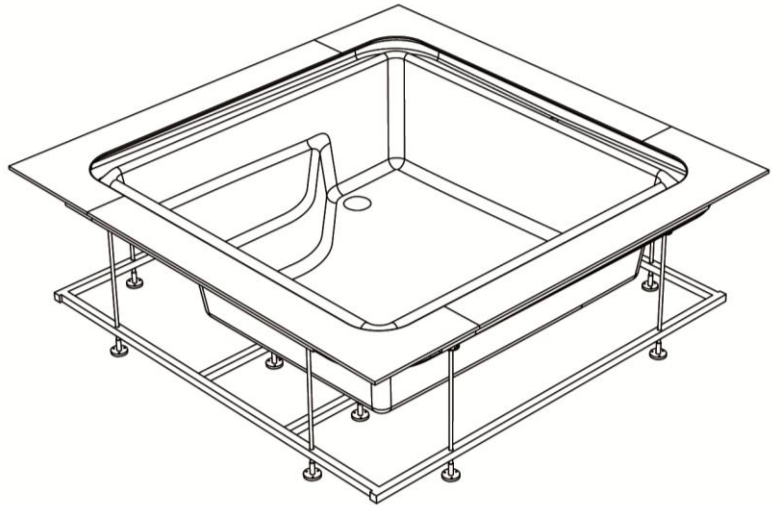

SYSTEMS	Electrical Characteristics				Nozzles		Water Cont.		Dimensions			Package			Weight	
	Volts	A	kW	Hz	Whirl	Air	use	max	length	width	Height	length	width	Height	Net	Gross
Digital whirl.	230	3.6 / 10.4*	0.8 / 2.3*	50	12	----	500	790	190	190	64	200	200	80	85	125
Airpool	230	3.2	0.7	50	----	24	500	790	190	190	64	200	200	80	80	114
Airpool Whirl.	230	6.8 / 13.6*	1.5 / 3.0*	50	12	24	500	790	190	190	64	200	200	80	95	135
Tube with frame	----	----	----	----	----	----	500	790	190	190	64	200	200	80	60	104

\* With option (1.5 kw heater)

The data must be considered without accessories.

The overall dimension values are expressed in centimetres. The actual dimensions may vary by  $\pm 0.5$  cm.

The product must also be connected to the building's equipotential system using the terminal located on the external frame.

If installing the tub encased between walls, the warranty will be valid only if adequate inspection grilles and ventilation are provided in the walls themselves.

It must also be possible to move the tub at any time without having to damage the walls.

**WARNING:** if the conditions indicated are not observed, the safety of the tub may be compromised: in this case, the product guarantee and the manufacturer's responsibility for any direct or indirect damage cause by the product shall be void.

In the case of a voided warranty, mentioned above, only single pieces deemed defective will be replaced. Any labour costs incurred for removal of the product will not be covered.

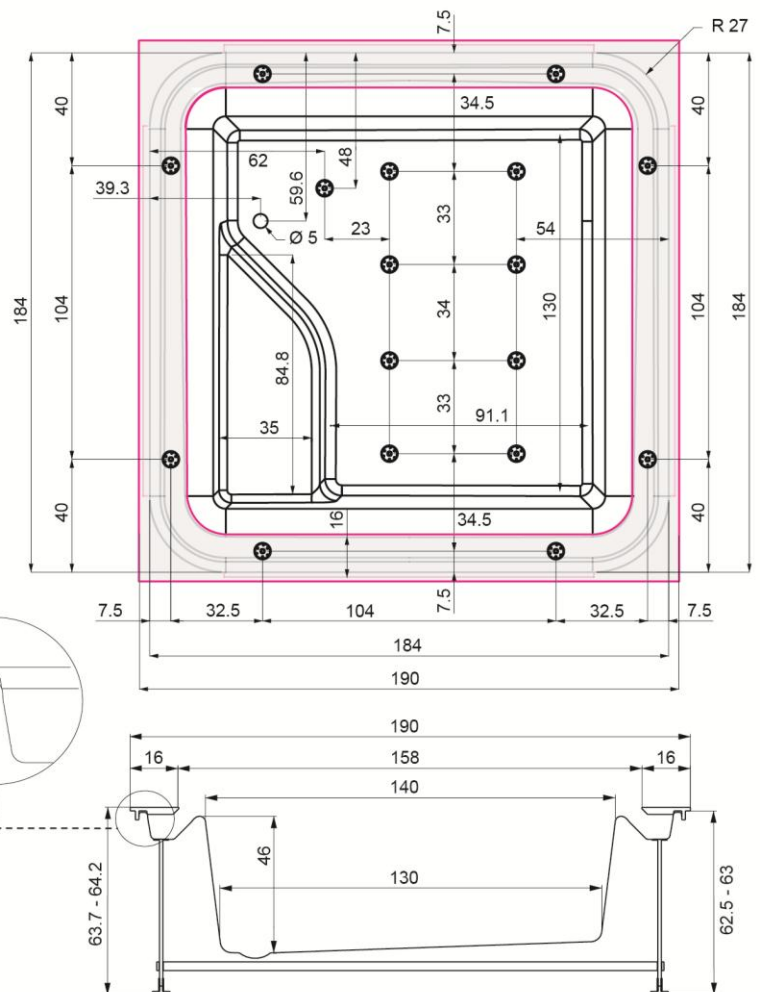

Provide for the inspection panel and air intake vent.

### KEY

- A - A1 - Mixed water outlet (connects to attachment F).
- B - B1 - H05 3x2.5 mm power cable outlet (min. length 3 [m])
- C - C1 - Equipotential cable.
- S - S1 - Drain at floor level Ø 50 or wall drain Ø 50.
- S2 - Secondary safety drain.\*

### PRESETTING FOR BUILT-TUB WITH WALL CONNECTIONS

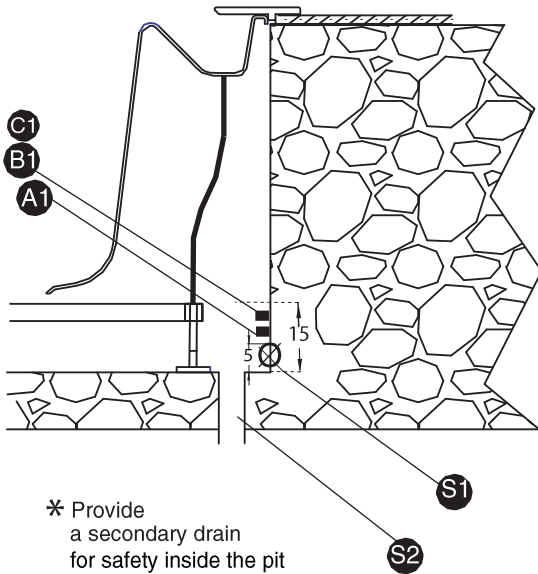

\* Provide a secondary drain for safety inside the pit for any water spillage.

### PRESETTING FOR BUILT-IN TUB WITH FLOOR CONNECTIONS

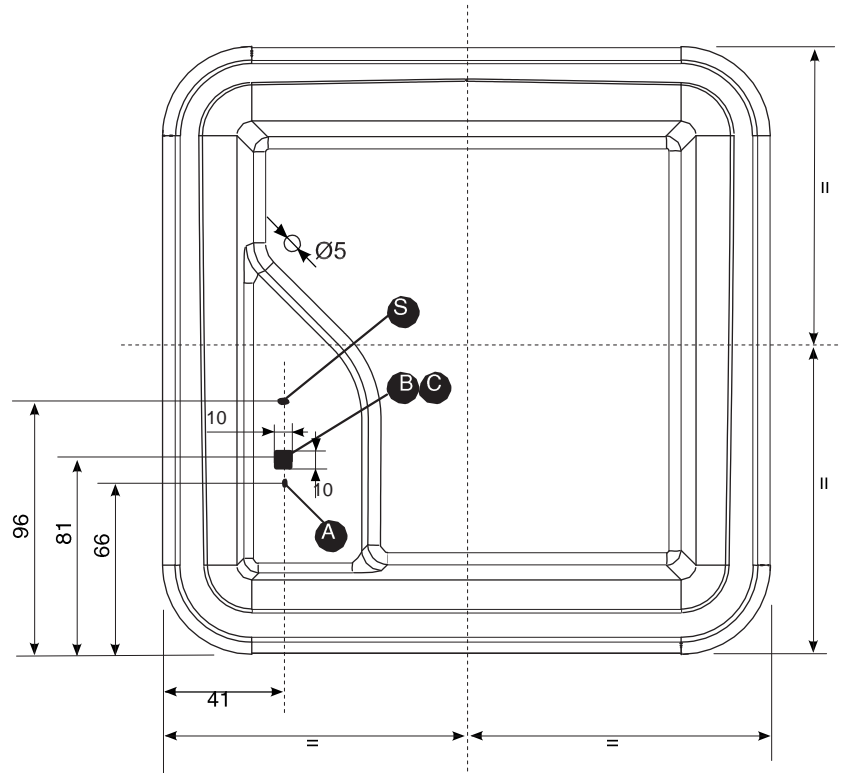

**Note:**  
- Pre-set connections in the pit wall that are no higher than the height of the frame, max 15 cm.

**NOTES:**  
- For tubs with frame, do not provide a power cable.  
- In all cases, always prepare the cable for the equipotential.

### POSITIONING CONTROLS AND INSPECTION BOLLA 190 Q DIGITAL WHIRPOOL - AIRPOOL - AIRPOOL WHIRPOOL

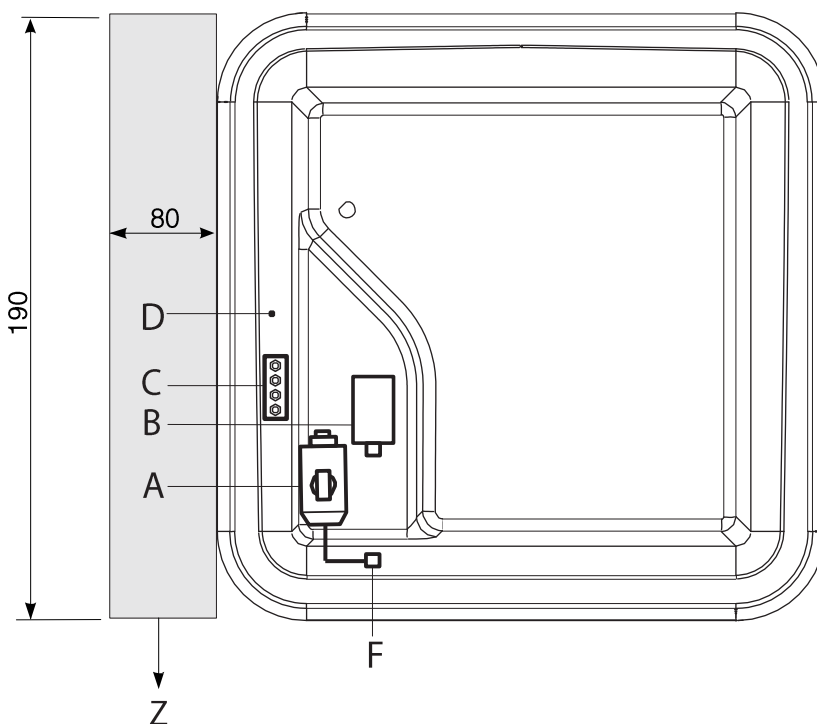

- A = Motor - Not including Airpool tubs
- B = Blower - Not including Digital Whirpool tubs
- C = Electrical control unit
- D = Keypad
- F = 1/2" water inlet

Z = INSPECTION AREA LOCATED UNDER THE SEAT.

The position of components A-B-C-D-F may vary in tubs with accessories (chromotherapy - heater).

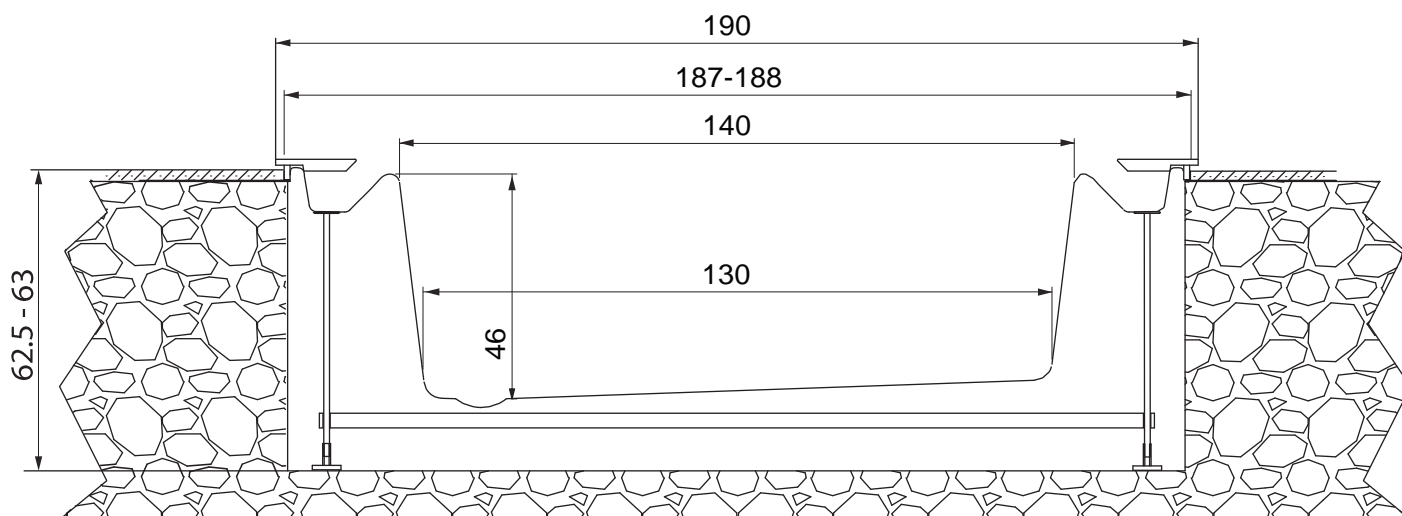

**HOLE FOR TUB ENCASEMENT**

