

BOLLA SFIORO 190Q with automatic recirculation system

technical data sheet



The tub must be installed by personnel qualified in both electrical and hydraulic connections.

Before making the connections, the installer must verify that the electrical system is protected by a differential switch (0.03) and that the earthing system complies with regulations in force in the county of use.

The whirlpool tub must be connected to the electrical system in a fixed manner (with three-pole H05 - 3 x 4 mm² with a cross-section 4 mm²) using a bipolar switch (minimum contact opening 3 mm) suitable for the power (kW) of the product to be connected and located outside zones 0, 1, 2 and 3 and away from any possible water sprays.

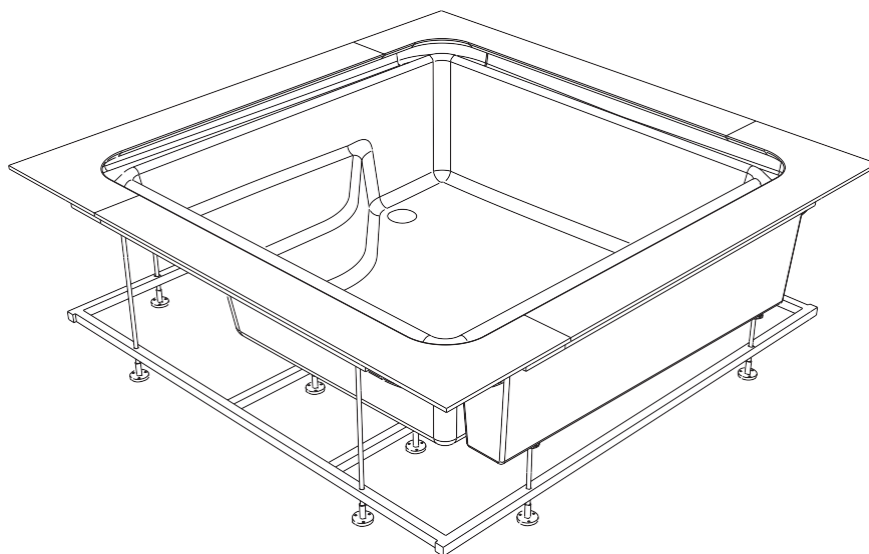

SYSTEMS	Electrical Characteristics				Nozzles		Water Cont.		Dimensions			Pack. Dimensions			Weight	
	Volts	A	kW	Hz	Whirl	Air	use	max	length	width	height	length	width	height	net	gross
Airpool	230	20	4.3	50	---	24	500	850	190	190	64	200	200	80	120	164

The data must be considered without accessories.

The overall dimension values are expressed in centimetres. The actual dimensions may vary by ± 0.5 cm.

The product must also be connected to the building's equipotential system using the terminal located on the external frame.

If installing the tub encased between walls, the warranty will be valid only if adequate inspection grilles and ventilation are provided in the walls themselves.

It must also be possible to move the tub at any time without having to damage the walls.

WARNING: if the conditions indicated are not observed, the safety of the tub may be compromised: in this case, the product guarantee and the manufacturer's responsibility for any direct or indirect damage cause by the product shall be void.

In the case of a voided warranty, mentioned above, only single pieces deemed defective will be replaced. Any labour costs incurred for removal of the product will not be covered.

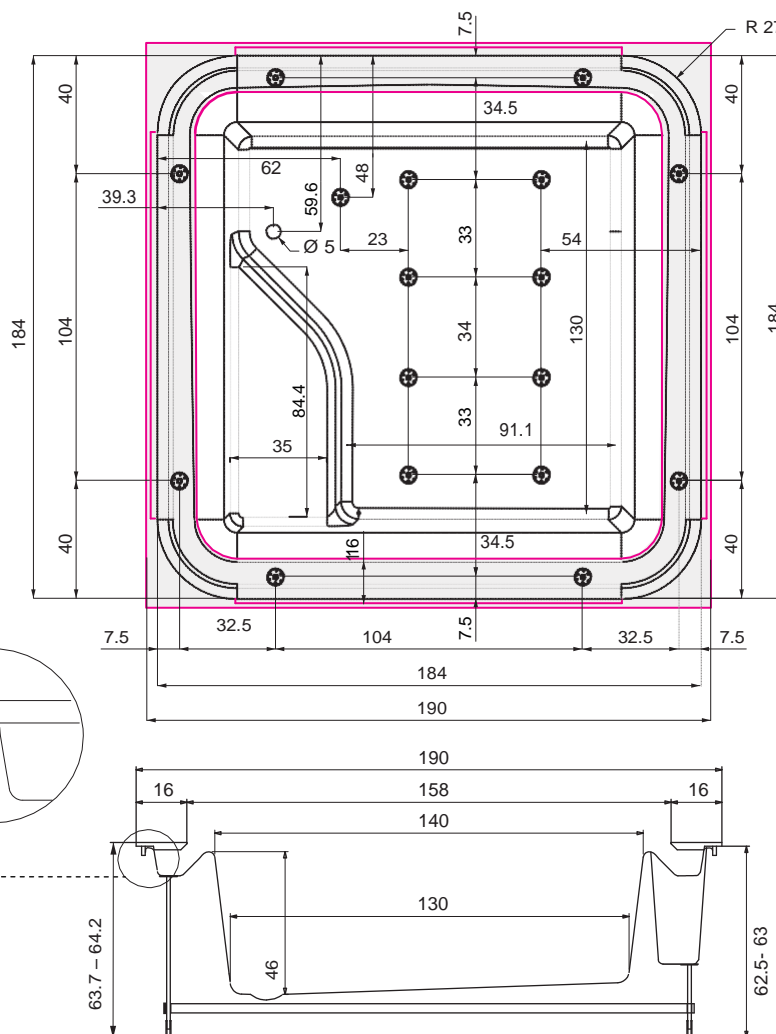

Provide for the inspection panel and air intake vent.

KEY

- S - S1** - Drain at floor level Ø 5 or wall drain Ø 5.
- S2** - Secondary safety drain*
- B - B1** - H05 3 x 4 mm power cable outlet (min. length 2 [m])
- C - C1** - Equipotential cable.
- D - D1** - Mixed water outlet (connects to attachment F)

PRESETTING FOR BUILT-IN TUB WITH WALL CONNECTIONS

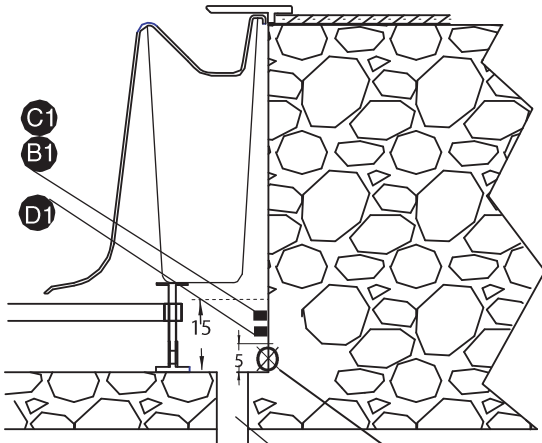

* Provide a secondary drain for safety inside the pit for any water spillage.

PRESETTING FOR BUILT-IN TUB WITH FLOOR CONNECTIONS

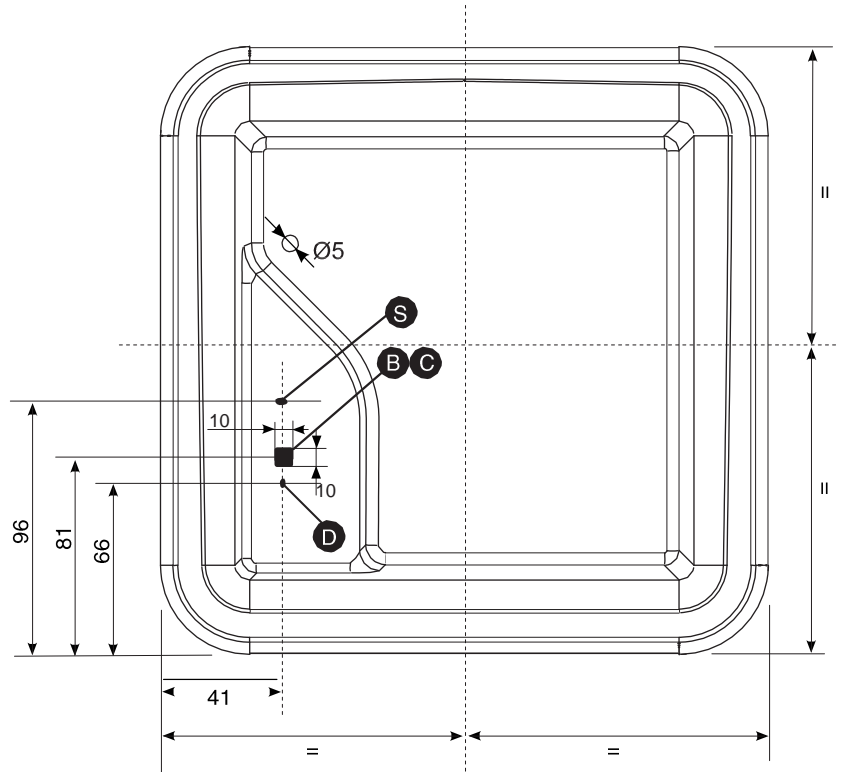

Note:

- Pre-set connections in the pit wall that are no higher than the height of the frame, max 15 cm.

POSITIONING CONTROLS AND INSPECTION BOLLA 190 Q WITH AUTOMATIC WATER RECIRCULATION SYSTEM WITH TEMPERATURE CONTROL AND DISINFECTION

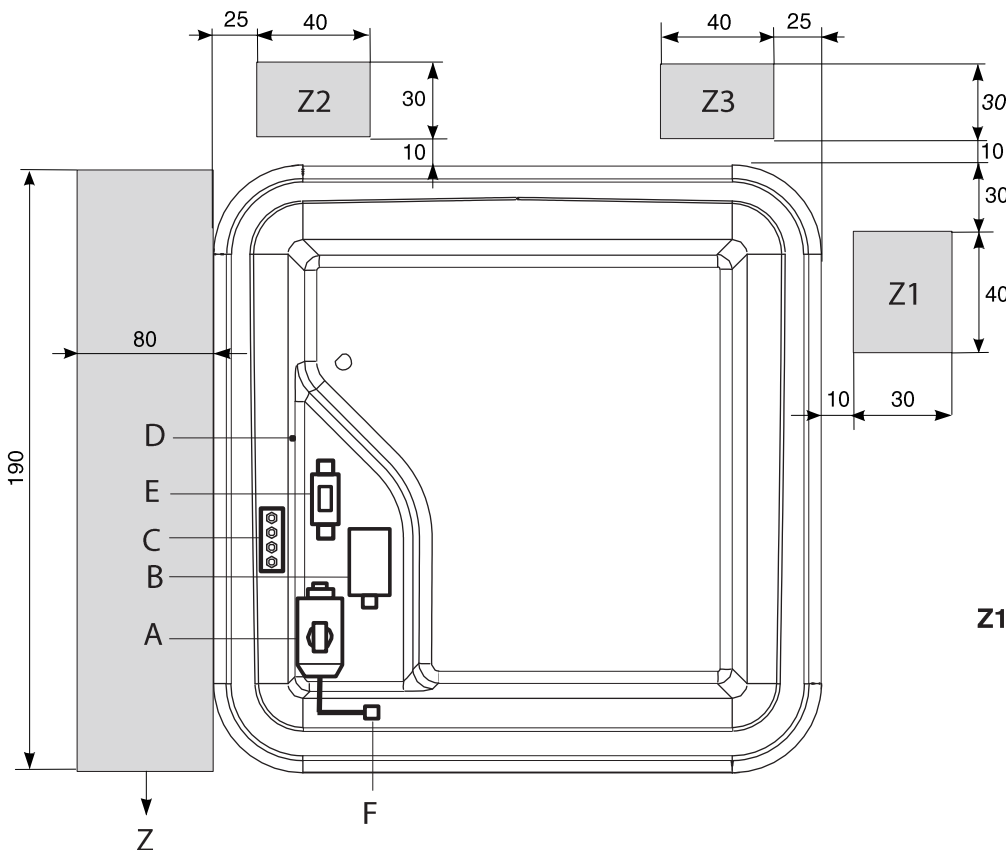

- A = Motor**
- B = Blower**
- C = Electrical control unit**
- D = Keypad**
- E = Heater**
- F = 1/2" water inlet**

Z = INSPECTION AREA LOCATED UNDER THE SEAT

Z1 - Z2 - Z3 = TANK FILTER INSPECTION AREA.

The position of components A-B-C-D-E-F may vary in tubs with accessories (chromotherapy) .

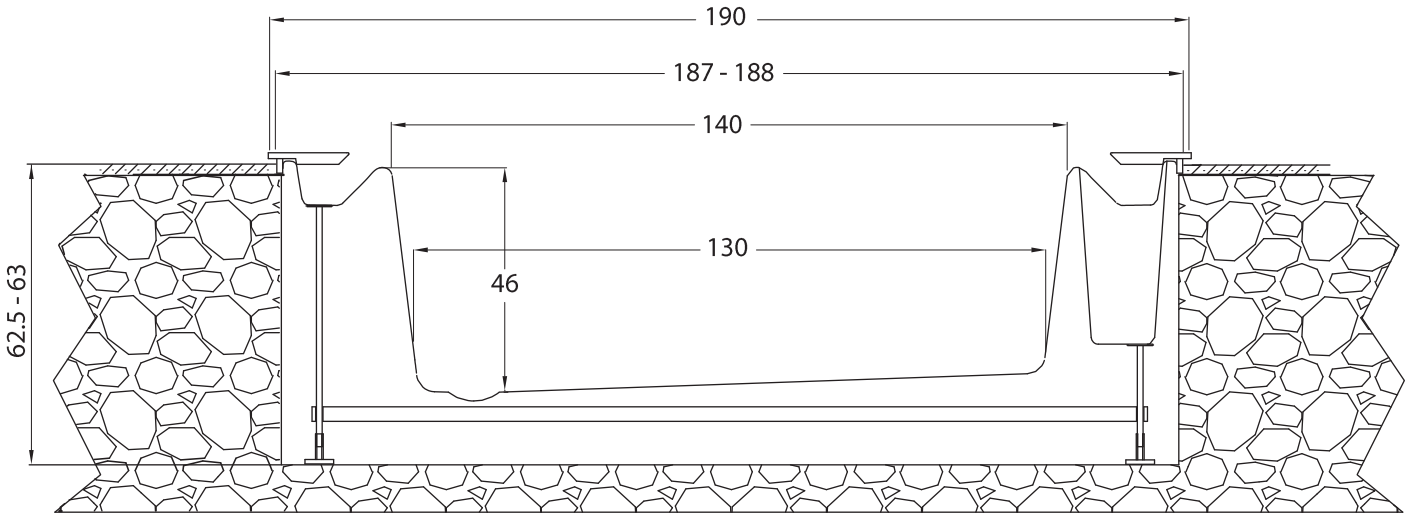

**HOLE FOR TUB
ENCASEMENT**

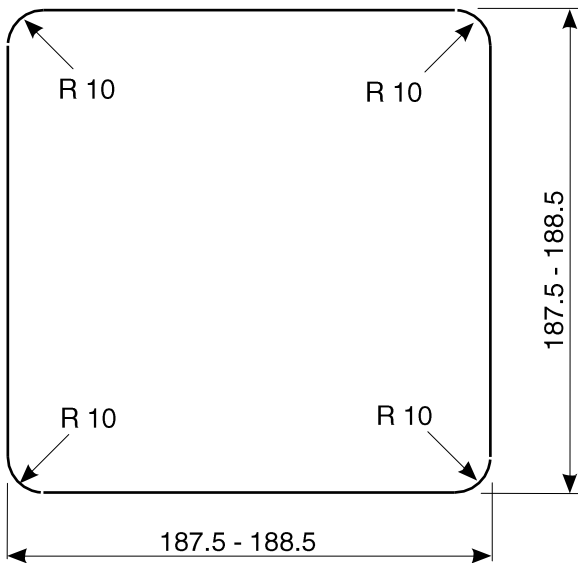

**Z1 - Z2 TANK FILTER
INSPECTION AREA**

