

BOLLA 160 Q

technical data sheet



The bath must be installed by a qualified electrician and plumber.

Before connecting the bath, the installer must see that the electrical system is protected by a circuit breaker (0.03) and that the earthing system complies with the laws in force in the country of installation.

The whirlpool bath must be connected to the electrical system permanently (with an H05 cable - 3x2.5 mm² three-pole with a 2.5 mm² cross section) by means of a double-pole switch (minimum 3 mm opening between contacts) and suitably rated (KW) for the appliance to be connected, located away from areas 0,1,2,3 and from areas where jets of water are possible.

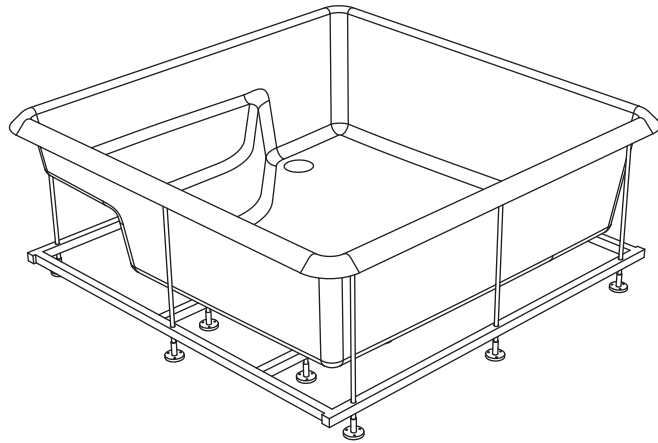

| SYSTEMS | Electrical specification | | | | Jet | | Water cont | | Siz | | | Packing dimension | | | Weight | |
|-----------------|--------------------------|---|-----|----|-------|-----|------------|-----|--------|-------|-------|-------------------|-------|--------|--------|------|
| | Volt | A | kW | Hz | Whirl | Air | use | max | length | width | width | length | width | height | net | gros |
| Airpool | 230 | 3 | 0,7 | 50 | — | 24 | 450 | 550 | 152.5 | 152.5 | 63 | 166 | 166 | 78 | 75 | 101 |
| Tube with frame | — | — | — | — | — | — | 450 | 550 | 152.5 | 152.5 | 63 | 166 | 166 | 78 | 50 | 76 |

The bath must also be connected to the building's equipotential earthing system by means of a terminal on the frame. If the bath is to be recessed in walls, the guarantee will only be valid if the walls are fitted with inspection and aeration grids of a suitable size. It is also important that the bath can be taken out at any time without having to do anything to the walls.

WARNING: if all or even part of the above described conditions are not complied with the safety of the whirlpool bath cannot be guaranteed and, as such, not only is the guarantee invalidated but also the manufacturer can in no way be held liable for any direct or indirect damages caused by the bath.

In those cases where such conditions are not complied with, the guarantee will only cover the substitution of parts deemed defective and not the labour needed if the bath has to be removed.

VIEW FROM ABOVE

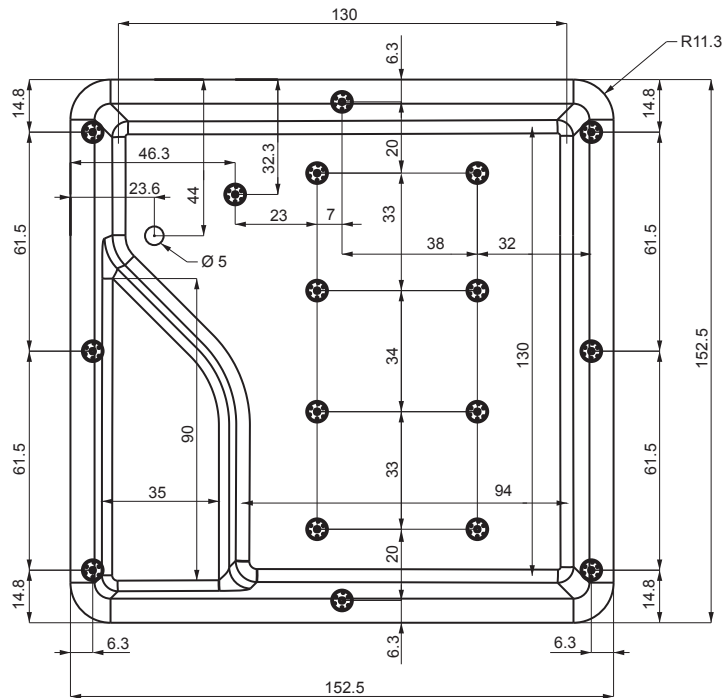

The overall dimensions are given in centimetres. Actual dimensions can vary by ± 1 cm.

SIDE VIEW

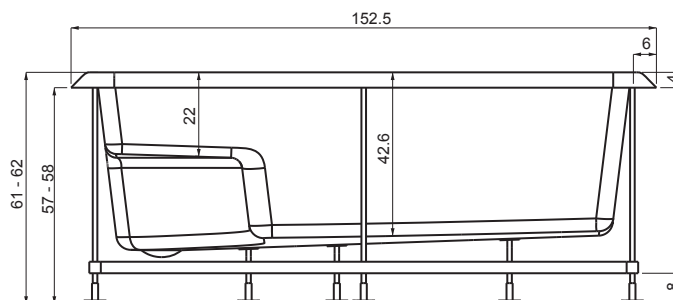

HOLE FLUSH TANK

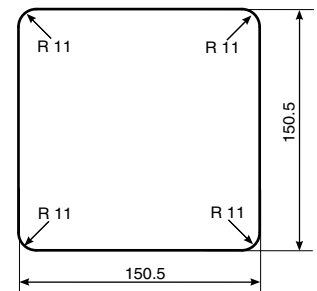

LEGENDA

- S - S1** - Flush to floor drain $\varnothing 5$, or wall drain $\varnothing 5$.
- B - B1** - Power outlet
H05 3x2,5mm (minimum. length. 2 [m]).
- C - C1** - Equalization cable.
- D - D1** - Mixed water outlet
(only for taps with E.T.P.)

ARRANGEMENT FOR BATH BUILT WITH CONNECTIONS TO THE FLOOR

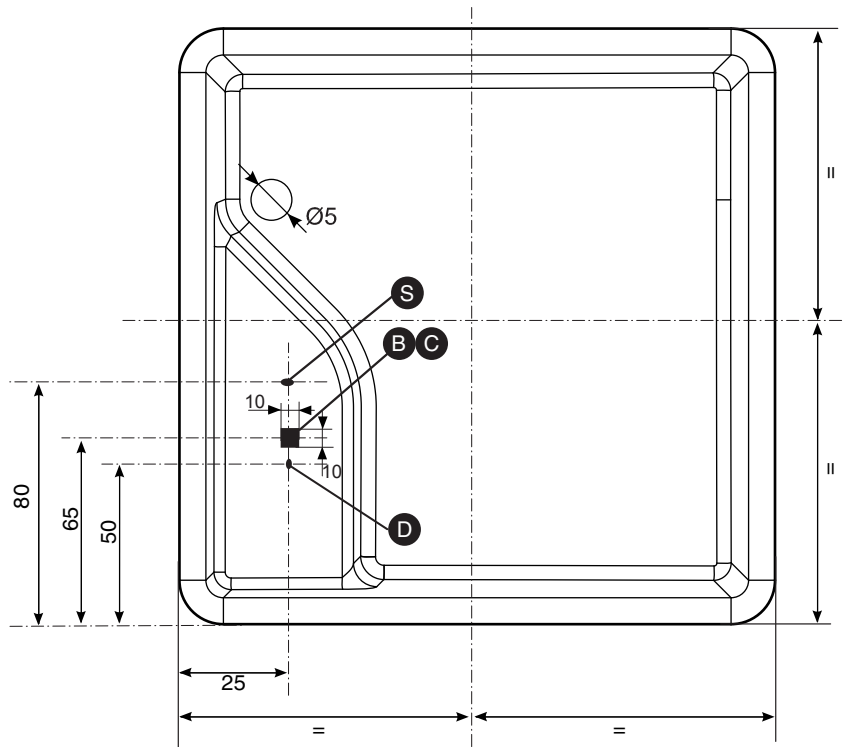

ARRANGEMENT FOR RECESSED BASIN WITH WALL MOUNTING

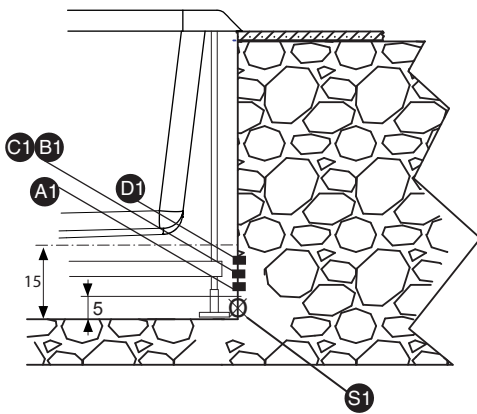

N.B.

If tub is built-in, please provide a secondary drain for any eventual water leaks.

Position of the outlets in the wall of the pit, haven't to be over the frame height up to 15cm.

NOTES

Do not prepare the power cable for baths with frame.

Prepare the equipotential cable in all cases

POSITIONING THE TURNING ON CONTROLS AND TAPS

Airpool

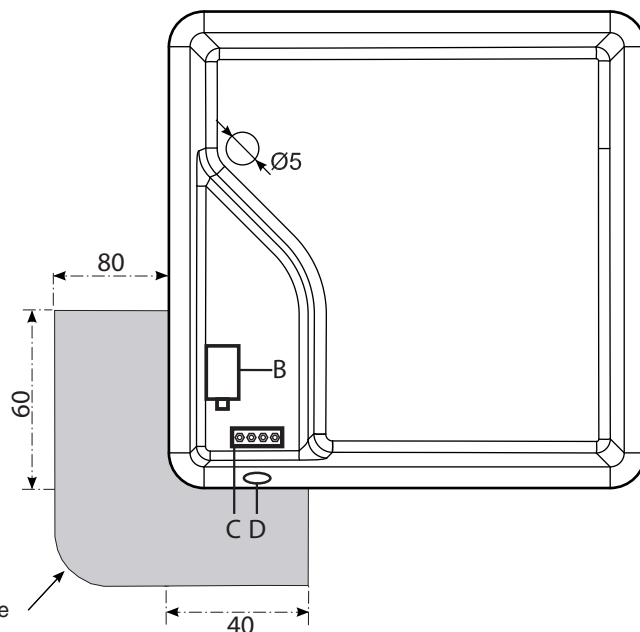

- Z = Service area.**
- A = Service area.**
- B = Blower**
- C = Eletronic unit.**
- D = Keyboard.**

Position can be different B - C - D according with accessories presence (chromoterapy).

Z - Area that should be left for inspection .