

BOLLA 160

technical data sheet



The bath must be installed by a qualified electrician and plumber.

Before connecting the bath, the installer must see that the electrical system is protected by a circuit breaker (0.03) and that the earthing system complies with the laws in force in the country of installation.

The whirlpool bath must be connected to the electrical system permanently (with an H05 cable - 3x2.5 mm² three-pole with a 2.5 mm² cross section) by means of a double-pole switch (minimum 3 mm opening between contacts) and suitably rated (KW) for the appliance to be connected, located away from areas 0,1,2,3 and from areas where jets of water are possible.

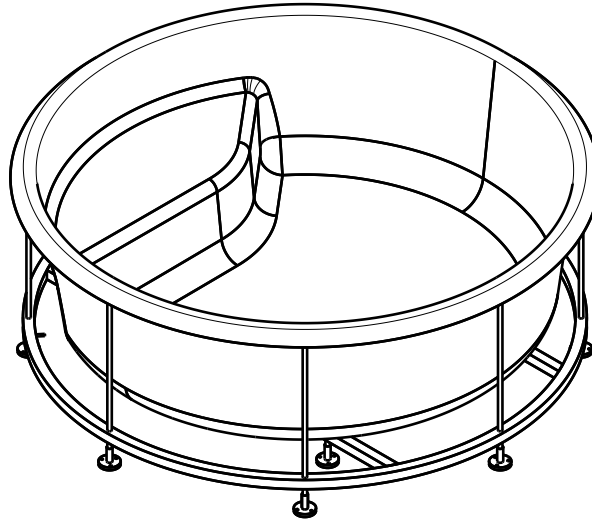

SYSTEMS	Electrical specification				Jet		Water cont		Siz			Packing dimension			Weight	
	Volt	A	kW	Hz	Whirl	Air	use	max	diamet.	width	length	width	height	net	gross	
Airpool	230	3	0,7	50	—	24	420	483	156	—	61	166	166	78	60	86
Tube with frame	—	—	—	—	—	—	420	483	156	—	61	166	166	78	50	76

The bath must also be connected to the building's equipotential earthing system by means of a terminal on the frame. If the bath is to be recessed in walls, the guarantee will only be valid if the walls are fitted with inspection and aeration grids of a suitable size. It is also important that the bath can be taken out at any time without having to do anything to the walls.

WARNING: if all or even part of the above described conditions are not complied with the safety of the whirlpool bath cannot be guaranteed and, as such, not only is the guarantee invalidated but also the manufacturer can in no way be held liable for any direct or indirect damages caused by the bath.

In those cases where such conditions are not complied with, the guarantee will only cover the substitution of parts deemed defective and not the labour needed if the bath has to be removed.

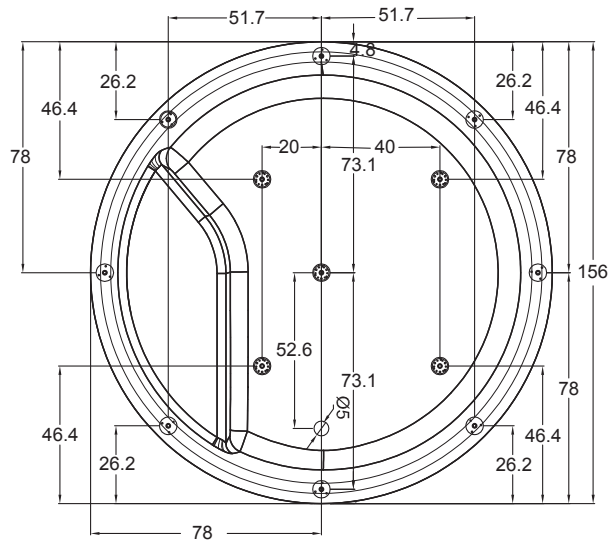

The overall dimensions are given in centimetres. Actual dimensions can vary by ± 1 cm.

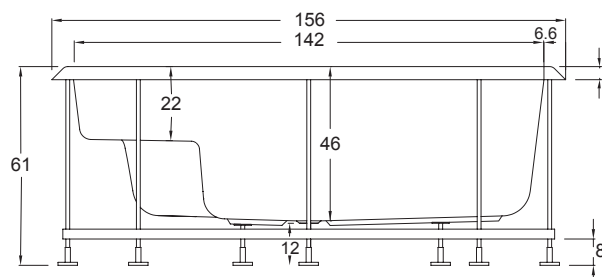

If the bath is recessed the masonry cannot reenter more than 1 cm with respect to the external edge of the bath. An inspection panel and air intake must be installed.

LEGEND

- A** - Inspection area.
- B** - Output for the power supply cable type H05 3x2.5mm² length M.2.
- B1** - Output for the equipotential cable
- C** - Draining area
- D** - Ø 50 floor drain.

NOTE:

Do not prepare the power cable for baths with frame.

Prepare the equipotential cable in all cases.

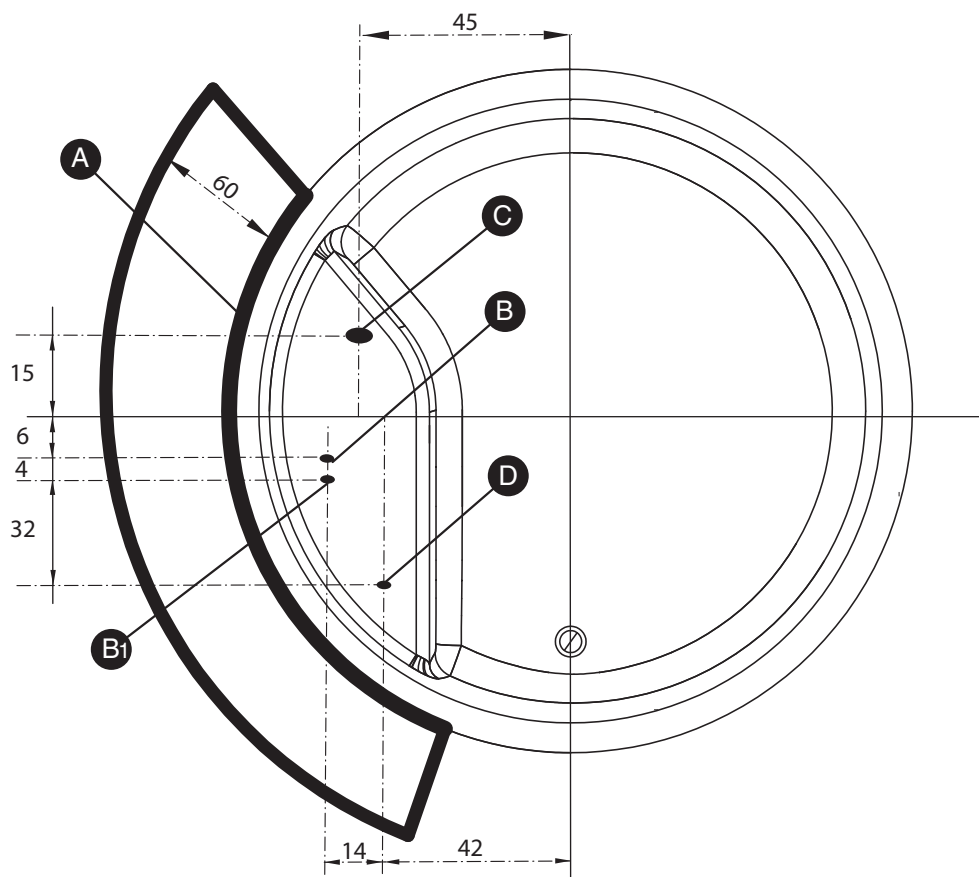

POSITIONING THE TURNING ON CONTROLS AND TAPS

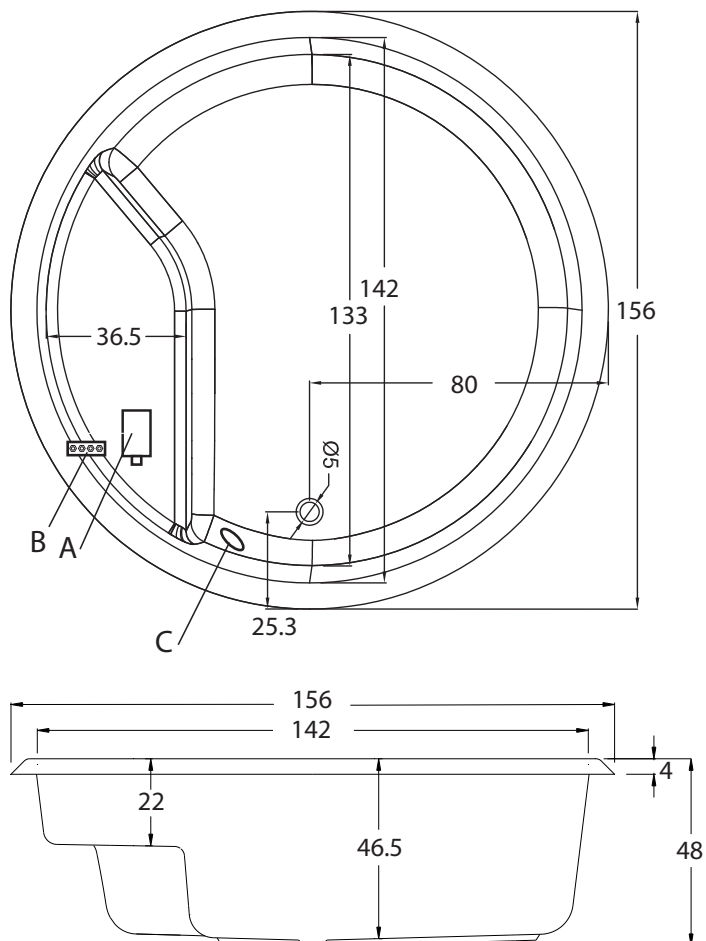

- A = Blower**
- B = Eletronic unit**
- C = Keyboard**

A - B - C Position can be different according with accessories presence (radio - chromoterapy - heater).